

**Global RTK Corrections for Monitoring
Displacements
Geo-Informatics**

”Versão final após defesa”

João Pedro Monteiro Fernandes

Dissertação para Obtenção do Grau de Mestre em
Engenharia Informática
(2º ciclo de estudos)

Orientador: Prof. Doutor Rui Manuel da Silva Fernandes

Covilhã, julho de 2022

Acknowledgements

I would like to thank my supervisor, Professor Rui Fernandes for his help and guidance throughout this journey.

For my friends and family a big thank you as well for the constant support during this period.

Resumo

O posicionamento preciso em tempo-real utilizando Sistemas de Posicionamento baseado em satélites, conhecido vulgarmente por *Global Navigation Satellite Systems (GNSS)* ou *Global Positioning System (GPS)*, é uma área intensiva de investigação, impulsionado principalmente por aplicações como condução autónoma ou a *Internet of Things (IoT)*. Métodos de posicionamento em tempo-real tradicionais utilizam estações de referência para corrigir a posição dos receptores em seu redor. Porém, estes métodos apresentam várias desvantagens, em particular o facto da qualidade da correção ser dependente da distância à estação, o que obriga à existência de redes densas de estações de referência. Métodos de posicionamento baseados em correções globais resolvem este problema de proximidade. Estes métodos são baseados no conceito em que os erros que afetam o posicionamento são modelados sobre largas áreas em vez da correção direta a partir das observações da estação(ões) de referência(s) mais próximas.

O objetivo desta dissertação é implementar um serviço que permita monitorizar a posição de estações permanentes de forma a que se possa detetar deslocamentos devido a causas humanas (e.g., deformação de um edifício) ou naturais (e.g., sismos ou vulcões) usando correções globais, permitindo assim a sua utilização em qualquer ponto da Terra.

Resumo alargado

Introdução

A necessidade de desenvolvimento de novos métodos de posicionamento é um grande desafio. Desde as primeiras aplicações civis do *GPS* que a evolução neste campo foi tremenda, com o lançamento de mais satélites, por sua vez mais avançados com o decorrer do tempo, assim como o desenvolvimento de sistemas alternativos, tais como o Galileo, o sistema de navegação por satélite da União Europeia. No entanto estes sistemas de localização possuem erros de posicionamento na casa dos metros.

Objetivos e Método Proposto

O projeto possui como principal objetivo o desenvolvimento e aplicação de uma solução que permita a nível global obter a posição corrigida de uma dada estação permanente GNSS, desde que possua uma ligação *Networked Transport of RTCM via Internet Protocol (NTRIP)* para a transmissão da sua posição em tempo-real, das efemérides dos satélites, e com isso, aplicando o método *Precise Point Positioning (PPP)* em conjunto com as correções globais providenciadas pelo Jet Propulsion Laboratory (JPL) em tempo-real, obter-se uma solução da posição final corrigida.

Estado da Arte

O *GNSS*, traduzido para português, Sistemas Globais de Navegação por Satélite é um termo utilizado para descrever todos os sistemas de navegação que fornecem ao utilizador uma solução de posicionamento tridimensional usando sinais de rádio transmitidos por satélites em órbita.

A posição do utilizador é calculada a partir de sinais transmitidos pelos satélites GNSS, os quais permitem saber a posição do utilizador utilizando o princípio da trilateração no espaço.

O *GNSS* inclui o sistema *GPS* dos Estados Unidos da América, o *Global Navigation Satellite System (GLONASS)* da Rússia, Beidou da China, *Quasi-Zenith Satellite System (QZSS)* do Japão e o Galileo da Europa.

O Real-Time Kinematic (RTK) é um método de posicionamento que utiliza o sistema *GNSS* em conjunto com uma *stream* de uma estação de referência para atingir precisões ao nível centimétrico. Esta técnica possui uma panóplia de aplicações, tais como monitorização de estruturas e de atividade sísmica, o posicionamento de drones e carros autónomos, para fazer levantamentos e mapeamentos, entre outros.

Portugal Continental possui duas redes de estações de referência permanentes, a rede Sistema de Estações de Referência GNSS VIRTuais (SERVIR) e a Rede Nacional de Estações Permanentes (RENEP) para a utilização de RTK em Portugal.

Resultados e Discussão

Através do método implementado foram comparadas as próprias correções obtidas com as provenientes do JPL, a grande diferença entre estes métodos reside no tempo de convergência inicial nas soluções provenientes do JPL em relação ao método proposto, devendo-se ao tempo necessário a que o método de *Real-time Precise Point Positioning (RT-PPP)* necessita para convergir as posições.

Foi observado que consoante a resolução de ambiguidade escolhida as soluções das posições iam-se alterando com maior variação no método “*Fix and Hold*” e menor variação no método “*Continuous*”. Derivado a uma maior peso das soluções anteriores no método “*Continuous*” em comparação com o “*Fix and Hold*”.

Conclusões e Trabalho Futuro

As aplicações de posicionamento em tempo-real encontram-se em proliferação, permitindo uma ampla gama de possíveis aplicações.

Estas aplicações usam métodos GNSS para obterem as posições em tempo-real, o método proposto permite alcançar precisões na ordem de alguns centímetros na posição corrigida, sendo apenas necessária uma ligação à Internet.

O método de correções globais foi implementado descartando a necessidade de estações de referência próximas, necessitando apenas de uma conexão à Internet para poder realizar as correções, permitindo o posicionamento preciso contínuo o que pode ser utilizado para estudar deslocamentos em estações permanentes, principalmente em áreas que carecem de infraestrutura necessária para se utilizar o RTK tradicional.

Em relação a trabalhos futuros, melhorias podem ser feitas quanto ao método implementado, por exemplo fazendo melhorias no algoritmo de *PPP*.

Outra sugestão passará por testar o método implementado usando um *Rover* no campo para avaliar a qualidade das soluções obtidas assim como trabalhos de mapeamento em relação a um sistema de referência nacional.

Palavras-chave

Sistemas Globais de Navegação por Satélite, Posicionamento de ponto preciso em tempo-real, Correções em tempo-real, Mensagens SSR

Abstract

Developing solutions for real-time positioning is on high demand, conducted by autonomous technologies and IoT.

The traditional RTK uses reference stations to correct the position in real-time, however this method has disadvantages, with the need of permanent stations nearby being the bigger one, as well as the lack of scalability.

Methods of positioning in real-time using State Space Representation (SSR) messages solve the need of stations in the vicinity. The proposed method in this dissertation adopts SSR messages to correct the positioning, using an open source program package for GNSS positioning named RTKLIB.

The main goal of this dissertation is to compute and analyze the final solutions and verify if it is possible to monitor stations in real-time using the proposed method.

Keywords

Global Satellite Navigation Systems, Real-time Precise Point Positioning, Real-time Corrections, SSR Messages

Contents

1	Introduction	1
1.1	Motivation and Scope	1
1.2	Objectives and Proposed Method	1
1.3	Document Organization	2
2	Basic Concepts	3
2.1	Introduction	3
2.2	Positioning	3
2.3	GNSS	3
2.4	Reference Systems	6
2.4.1	Earth-centered, Earth-fixed (ECEF)	6
2.4.2	East North Up (ENU)	7
2.4.3	World Geodetic System 1984 (WGS 84)	8
2.5	Radio Technical Commission for Maritime Services (RTCM) messages	8
2.5.1	RTCM-Observation Space Representation (OSR) messages	9
2.5.2	RTCM-SSR messages	9
2.6	NTRIP	10
2.7	Reference Stations	11
3	State of the Art	13
3.1	Introduction	13
3.2	Real-Time Kinematic	13
3.2.1	Applications of RTK	14
3.2.2	Advantages of RTK	14
3.2.3	Disadvantages of RTK	15
3.2.4	Regional networks	15
3.3	Global SSR networks	17
3.3.1	PPP-Wizard CNES network	18
3.3.2	International GNSS Service (IGS) network	19
3.3.3	Galileo High Accuracy Service	19
3.4	Comparative of OSR with SSR	20
3.5	RT-PPP	21
3.6	IGS	22
3.7	Conclusion	22
4	Methods	23
4.1	Introduction	23
4.2	Methods	23
4.3	Materials	24
4.3.1	SSR corrections	24

4.3.2	RTKLIB	25
4.3.3	GNSS receivers	27
4.3.4	Virtual Machine	28
4.3.5	GEODAC	28
4.3.6	Tunnel	28
4.3.7	NetCat	28
4.3.8	Tenex C Shell	29
4.3.9	Python	29
4.3.10	Portal	29
4.3.11	Statistics	29
4.4	Implementation	31
5	Results and Discussion	37
5.1	Introduction	37
5.2	Results	37
5.2.1	Fix and Hold	38
5.2.2	Continuous	39
5.2.3	Instantaneous	40
5.2.4	Height measurement	40
5.2.5	PAGU station	43
5.2.6	SSSV station	47
5.2.7	JBEI station	48
5.3	Discussion	49
6	Conclusions and Future Work	51
6.1	Conclusions	51
6.2	Future Work	51
	Bibliography	53

List of Figures

2.1	Trilateration, image taken from [gis22].	4
2.2	GNSS architecture, image taken from [nov22].	5
2.3	Geocentric ECEF Coordinate System, image taken from [wwh22].	7
2.4	ECEF and ENU system, image taken from [dir22].	7
2.5	WGS 84 system, image taken from [EA415].	8
2.6	NTRIP network, image taken from [ard22].	10
3.1	Concept of Real-Time Kinematic.	13
3.2	Monitoring of bridge using RTK, image taken from [GXD ⁺ 05].	14
3.3	SERVIR and RENEP network of stations in Portugal [dS16], [dT].	16
3.4	São Jorge Island and respective stations, image from [MIR22].	17
3.5	PPP-Wizard network of stations in the World [CNE21].	18
3.6	IGS network of stations in the World [IGS22b].	19
3.7	High Accuracy Service (HAS) network of stations in the World [DB21].	19
3.8	Message Format Comparison, image taken from [Age21].	20
3.9	SSR and OSR implentation [Geo15].	21
4.1	Implemented Network Schema.	24
4.2	RTKNAVI Graphical user interface (GUI) on the startup.	26
4.3	RT-PPP schema flow in RTKNAVI, schema from RTKLIB manual [Tak13].	26
4.4	Trimble NETR9 GNSS receiver, image taken from [Aim22].	27
4.5	Septentrio PolaRx5, image taken from [Sep22].	28
4.6	Example of an output file from a station.	32
5.1	Movable Rover used.	37
5.2	Movable Rover used.	38
5.3	Fix and Hold experiment.	39
5.4	Continuous experiment.	39
5.5	Instantaneous experiment.	40
5.6	1.52 meter height of the Rover.	41
5.7	2 meter height of the Rover.	41
5.8	PPP Height measurement.	42
5.9	Rover Height zoomed.	43
5.10	Solutions displayed in real-time.	43
5.11	PAGU Method Fix and Hold for the full day.	44
5.12	PAGU JPL solution for the full day.	45
5.13	PAGU station position graph using the JPL solutions.	46
5.14	NEU difference between methods for PAGU.	47

List of Tables

2.1	RTCM SSR messages spectrum, table taken from [fMS13].	9
3.1	Comparison between SSR and OSR	21
4.1	SSR Message Envelope, image taken from [JPL17].	25
5.1	Statistics (standard deviation and residuals) for the North component of PAGU station.	45
5.2	Statistics (standard deviation and residuals) for the East component of PAGU station.	45
5.3	Statistics (standard deviation and residuals) for the Up component of PAGU station.	45
5.4	Table comparing the two methods regarding the X field.	46
5.5	Table comparing the two methods regarding the Y field.	46
5.6	Table comparing the two methods regarding the Z field.	46
5.7	Statistics comparing the two methods regarding the North component. . .	47
5.8	Statistics comparing the two methods regarding the East component. . . .	47
5.9	Statistics comparing the two methods regarding the Up component.	47
5.10	Statistics (standard deviation and residuals) for the North component of SSSV station.	48
5.11	Statistics (standard deviation and residuals) for the East component of SSSV station.	48
5.12	Statistics (standard deviation and residuals) for the Up component of SSSV station.	48
5.13	Statistics (standard deviation and residuals) for the North component of JBEI station.	48
5.14	Statistics (standard deviation and residuals) for the East component of JBEI station.	48
5.15	Statistics (standard deviation and residuals) for the Up component of JBEI station.	49

Acronyms List

BDS	BeiDou Navigation Satellite System
CNES	Centre National d'Études Spatiales
CORS	Continuously Operating Reference Stations
CRC	Cyclical Redundancy Check
CSH	C shell
CTRS	Conventional Terrestrial Reference System
CUI	Character User Interface
C4G	Collaboratory for Geosciences
DGT	Direção-Geral do Território
Doy	Day of year
ECEF	Earth-centered, Earth-fixed
ENU	East North Up
GB	Gigabyte
GLONASS	Global Navigation Satellite System
GNSS	Global Navigation Satellite Systems
GPS	Global Positioning System
GUI	Graphical user interface
HAS	High Accuracy Service
HTTP	Hypertext Transfer Protocol
IoT	Internet of Things
IGS	International GNSS Service
IPMA	Instituto Português do Mar e da Atmosfera
ITRF	International Terrestrial Reference Frame
ITRS	International Terrestrial Reference System
JPL	Jet Propulsion Laboratory
NAS	Network Attached Storage

Global RTK Corrections

NASA	National Aeronautics and Space Administration
NCAT	NetCat
NMEA	National Marine Electronics Association
NTRIP	Networked Transport of RTCM via Internet Protocol
OS	Operating System
OSR	Observation Space Representation
PPP	Precise Point Positioning
PPP-AR	Precise Point Positioning with ambiguity resolution
QZSS	Quasi-Zenith Satellite System
RAM	Random Access Memory
RENEP	Rede Nacional de Estações Permanentes
REPRAA	Rede de Estações Permanentes Região Autónoma dos Açores
RHEL	Red Hat Enterprise Linux
RNP	Required Navigation Performance
RTCM	Radio Technical Commission for Maritime Services
RTCM-CSSR	Radio Technical Commission for Maritime Services - Compact State Space Representation
RT-PPP	Real-time Precise Point Positioning
RTK	Real-Time Kinematic
SEGAL	Space and Earth Geodetic Analysis Laboratory
SERVIR	Sistema de Estações de Referência GNSS VIRTuais
SIM	Subscriber Identity Module
SSR	State Space Representation
TCP	Transmission Control Protocol
TCP/IP	Transmission Control Protocol/Internet Protocol
TCSH	Tenex C Shell
UBI	Universidade da Beira Interior
UHF	Ultrahigh Frequency
WGS 84	World Geodetic System 1984

Chapter 1

Introduction

1.1 Motivation and Scope

The need to develop new positioning methods is of great challenge. From the first civilian applications of the Global Positioning System (GPS), the evolution in this field has been tremendous, with the launch of more satellites, technologically advanced over time, as well as the development of alternatives such as Galileo, the European Union's satellite navigation system, Global Navigation Satellite System (GLONASS) from Russia, Beidou from China and Quasi-Zenith Satellite System (QZSS) from Japan. However, these systems have positioning errors in the meters, tolerable errors for navigation use, but not precise enough for high precision measurements. A solution for that was the implementation of Real-Time Kinematic (RTK) using base stations as reference.

The use of techniques using Global Navigation Satellite Systems (GNSS) for the positioning in real-time are on high demand, which is leading to the development of newer and improved methods for accomplishing it, compared to the conventional RTK. One of the techniques that has been developed is the use of State Space Representation (SSR) messages for obtaining the positions in real-time with great accuracy. This type of messages can be used for obtaining an accurate position without the need of base stations in the surrounding area with the corrections being broadcast via Internet with a low bandwidth at reducing costs.

The applications of this method are extensive, autonomous driving is technology that can benefit from such type of positioning in real-time, for example, self-driving autonomous cars being developed, self-flying drones are in need of a improved accuracy in real-time for a better performance in real world. Other possible implementation for these methods is the monitoring of infrastructures like bridges or large buildings.

The scope of the method is to implement a viable solution, using this new techniques based on SSR messages, which contain GNSS Combined Orbits and Clock Corrections, using this information the position will be corrected. These corrections are provided by JPL, a laboratory from NASA, that also made available their own solutions for some stations, which were used to evaluate the solutions computed by the implemented method.

1.2 Objectives and Proposed Method

The main objective proposed in this dissertation is to develop a solution that can compute accurate position solutions in real-time using the newer SSR messages provided by JPL. The method is implemented with the corrections provided by JPL, which is a laboratory of National Aeronautics and Space Administration (NASA), with whom Space and

Earth Geodetic Analysis Laboratory (SEGAL) has a strong cooperation and partnership with. Other organizations also provide this type of corrections, such as IGS [IGS22d] or GEO++ [GEO22].

Other methods have others disadvantages, regarding range, associated costs and accuracy as will be discussed after in chapter 3. The reference stations that are used to stream RTK corrections have relative large installation and operation costs, and they are only able to provide accurate corrections at short distances (<25-50 kilometers depending on the type of RTK solution).

Given a NTRIP connection with the positioning of a station, the proposed method with the corrections messages received in real-time from JPL, should be capable of correcting its positioning, globally, if there is a Internet connection available for receiving the SSR data streaming.

One of the main objectives of this method is to evaluate possible changes in the position of a station in real-time, for example if it was a natural phenomenon deformation, such as an earthquake, related to volcanology or on the other hand if it had non natural cause, for example, a person moving the antenna of the station. The recent events in the São Jorge Island in Azores, related to the seismic crisis in the beginning of 2022, was perceived as an opportunity to monitor in real-time the stations positioning using the proposed method.

1.3 Document Organization

- Chapter 1, **Introduction**, presents the motivation, the scope of this dissertation, the main objectives and the proposed method implemented concluding with the document organization;
- Chapter 2, **Basic Concepts**, explains the basic concepts relevant to this dissertation;
- Chapter 3, **State of the Art**, analyses previous methods used with the purpose of understanding how was it done and the main changes in between methods and the solutions obtained;
- Chapter 4, **Methods**, comprehends the implementation of the solution proposed in the project with the materials used;
- Chapter 5, **Results and Discussion**, the respective tests carried out and the discussion of them;
- Chapter 6, **Conclusions and Future Work**, establishes the main conclusions obtained from this project and addresses possible future work for improvements.

Chapter 2

Basic Concepts

2.1 Introduction

This chapter introduces basic concepts used in this dissertation, for a better comprehension in the following chapters.

2.2 Positioning

GNSS positioning is based on measuring the distances between positioning satellites and the user receiver. When the distances to several satellites are measured, the user receiver position can be computed by using the known positions of the satellites.

The distance measurement and its reliability is affected by several error sources. The accuracy of the user position can be improved by correcting the effect of the error sources on the distance measurements by using GNSS reference stations at known positions. The modelled size of the errors is sent to the user of a positioning service as corrections. The user receiver can use the corrections to improve the positioning accuracy [oF22].

2.3 GNSS

Global Navigation Satellite Systems or GNSS is the collective term for those navigation systems that provide the user with a three-dimensional positioning solution by passive ranging using radio signals transmitted by orbiting satellites [Gro15].

Calculating the location of points on or above the Earth is done by using signals sent from satellites orbiting the earth. The GNSS constellations includes the GPS of United States of America, GLONASS of Russia, Beidou of China, QZSS from Japan and Galileo of Europe. The receivers on the ground then use the data signals from the satellites to determine their location using trilateration, where all the spheres intersect determines the position of the GPS receiver, as observed in Figure 2.1. To get a position, a minimal of four stations are needed, since there are four unknowns: the three components of the position of the receiver in space plus a correction to the receiver's clock.

The fourth satellite is used to correct for the GPS receiver's clock error and find the precise position, small timing errors from all four satellites to the point on the Earth have been adjusted, and the exact location on the Earth can be determined [Ser22].

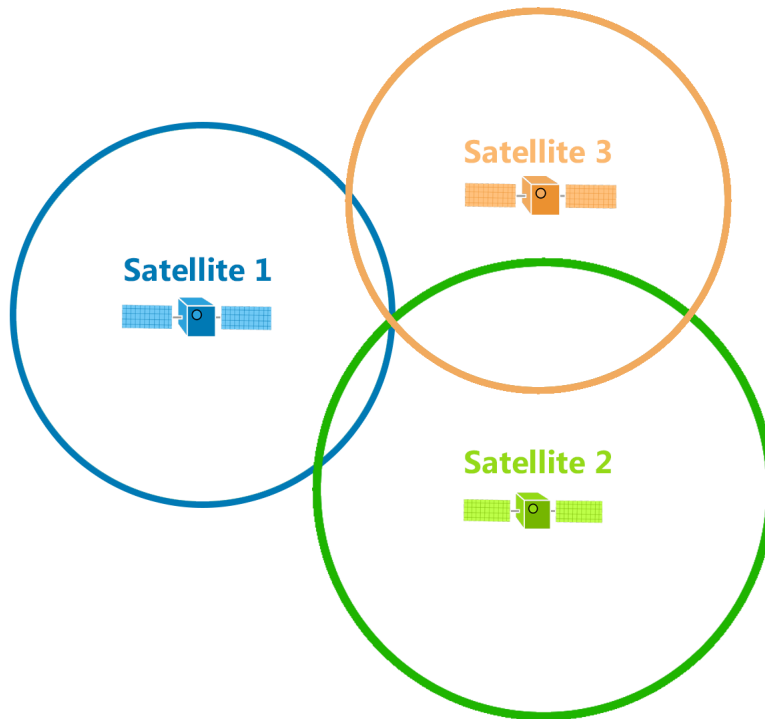

Figure 2.1: Trilateration, image taken from [gis22].

GNSS is used in all forms of transportation sectors, aviation, space stations, maritime, rail, road. Positioning, navigation and timing play a critical role in telecommunications, land surveying, law enforcement, emergency responses, precision agriculture, finance, mining, scientific research and much more [fOSA22].

Global RTK Corrections

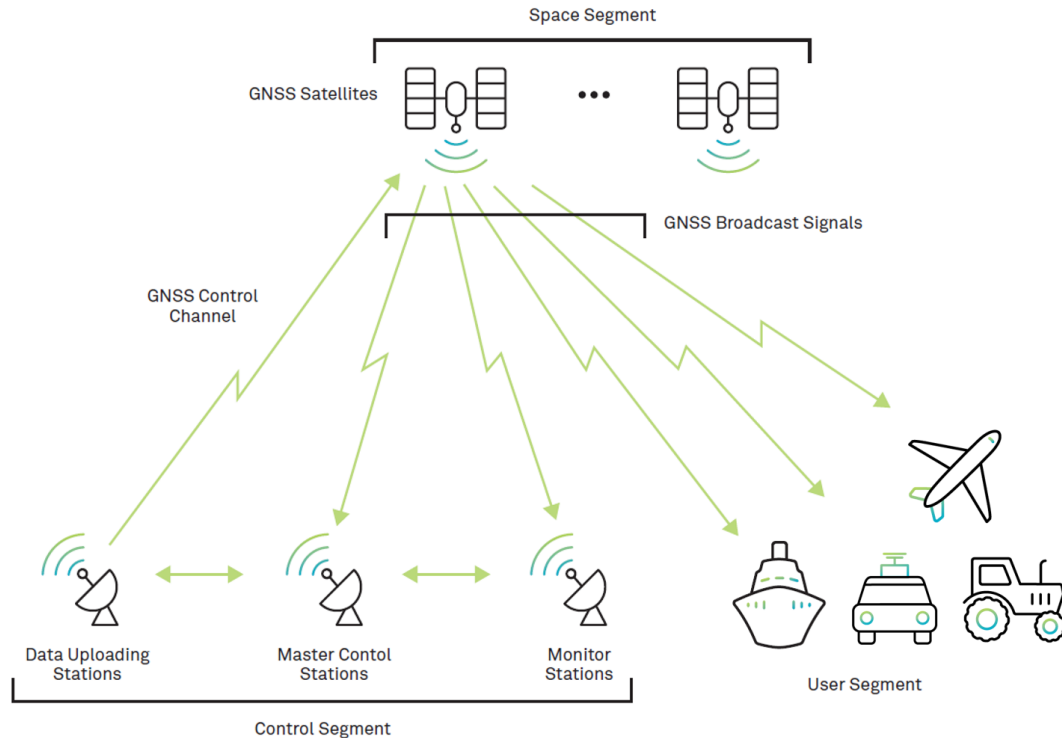

Figure 2.2: GNSS architecture, image taken from [nov22].

In Figure 2.2 the space segment describes the GNSS constellations orbiting between 20,000 to 36,000 kilometres above the Earth, broadcasting signals that identify which satellite is transmitting and its time, orbit and status or health.

The control segment is a network of master control, monitoring stations located around the world. These stations receive a satellite's signal and compare where the satellite says it is with orbit models showing where it should be.

These stations can control the satellites position to correct or alter their orbital paths, in case if a satellite has drifted of the correct orbit, or needs to be moved to avoid debris collision. This process, as well as monitoring a satellite's health, ensures a baseline of accuracy in GNSS positioning.

User segment includes the equipment that receives satellite signals, the receivers, and outputs a position based on the time and orbital location of at least four satellites, three for the positioning and a fourth for the time [nov22].

The applications of GNSS can be divided in the following fields [nov22]:

- **Location**, determining the position in the world;
- **Navigation**, identifying the best route from one point to another;
- **Mapping**, creating maps of a specific area;
- **Timing**, computing precise timing within billionths of a second;
- **Tracking**, monitoring an object's movement in the world.

The performance of GNSS is assessed using four criteria [Ser18] based on the Required Navigation Performance (RNP) [BEY16]:

1. **Accuracy**, the accuracy of an estimated or measured position to the real position, speed or time;
2. **Integrity**, a system's capacity to provide a threshold of confidence, including the ability of the system to provide timely warnings to users when the system should not be used for navigation;
3. **Continuity**, ability to function without interruption during the intended operation;
4. **Availability**, is the percentage of time that the services of the system are usable by the navigator.

2.4 Reference Systems

Satellites coordinates and user coordinates must be defined in known reference systems. Precise positioning by GNSS requires an accurate definition and determination of this reference system.

Geodetic coordinates, such as those obtained by GPS measurements, defined with respect to some reference system that comprises measurement techniques, models, computational formulas, conventions, and reference frame coordinates, which together allows users to compute their positions at any time and location within errors and limitations that might be specified [Mor80].

By their very nature, GNSS reference systems are global in scale, transcending international boundaries. Although continental or national reference systems are often derived from the global reference systems to satisfy national requirements, the mathematical relationship between the smaller-scale systems and the global systems is precisely specified. Hence, GNSS coordinates can be meaningfully compared between any points on or near the Earth's surface, be they on land, sea, or in the air [Ble16].

International Terrestrial Reference Frame (ITRF) is the realization of the International Terrestrial Reference System (ITRS). ITRS is used for the most demanding geodetic applications, for example Earth research, surveying and mapping. It is fundamentally based on the rigorous combination of geodetic products of the main space geodetic techniques, through their co-located measuring instruments at a certain number of core sites [ZA12]. The used reference systems in this dissertation was ECEF, described in section 2.4.1, ENU, described in section 2.4.2 and WGS 84, described in section 2.4.3.

2.4.1 ECEF

The Earth-centered, Earth-fixed (ECEF) is a system of geographic and Cartesian coordinates and is sometimes known as a "conventional terrestrial" system, represents positions as X, Y and Z coordinates. The point (0, 0, 0) is defined as the Earth's center of mass, hence the term geocentric coordinates. The units are expressed in meters.

Global RTK Corrections

General reference of ECEF is available in this book [XX16].

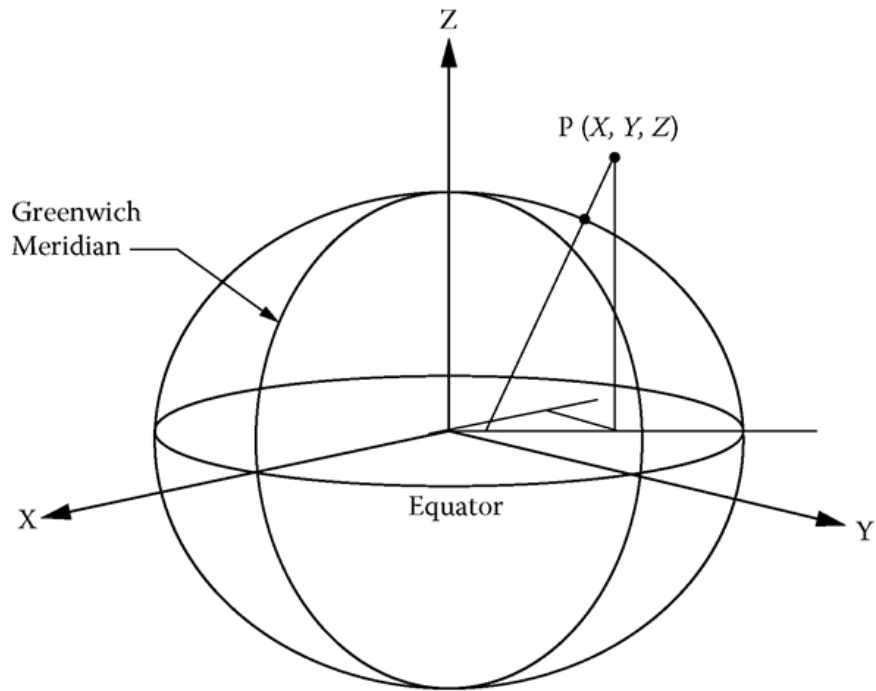

Figure 2.3: Geocentric ECEF Coordinate System, image taken from [wwh22].

Its X axis passes through the Greenwich meridian, its Z axis coincides with the Earth's axis of rotation, its Y axis lies in the equatorial plane, as observed in Figure 2.3.

2.4.2 ENU

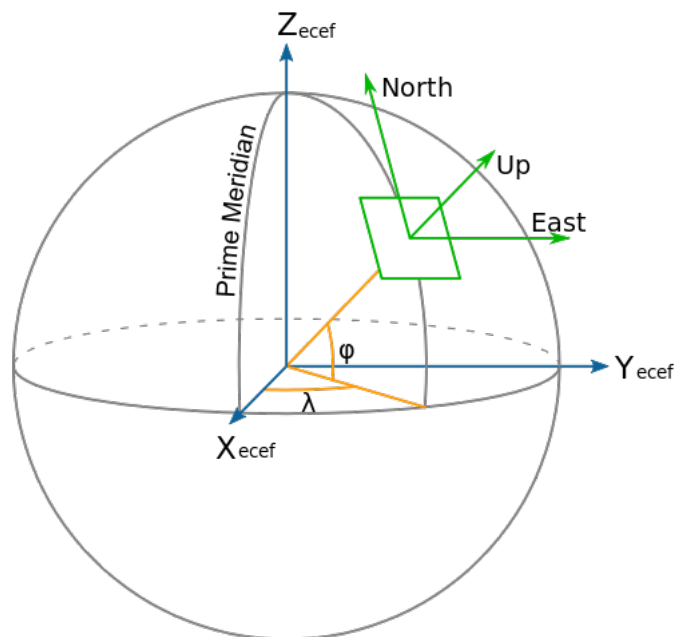

Figure 2.4: ECEF and ENU system, image taken from [dir22].

The local East North Up (ENU) coordinates are formed from a plane tangent to the Earth's surface fixed to a specific location, represented in Figure 2.4 and hence it is sometimes known as a "Local Tangent" or "local geodetic".

2.4.3 WGS 84

The World Geodetic System 1984 (WGS 84) is a Conventional Terrestrial Reference System (CTRS), which definition has been done by the department of Defense of the United States [DEF14]. Although it has been created for GPS it is the system used when GNSS coordinates are estimated.

Given GNSS ranging data recorded by a user's receiver, the receiver's coordinates (longitude, latitude, and height) can be computed in WGS 84.

While the WGS 84 reference frame coordinates are improved from time to time, the reference system maintains its name. Since its initial development, the WGS 84 reference frame has become considerably improved by making it consistent with a much higher accuracy reference system ITRF [Ble16].

The latitude and longitude are usually represented in radians while the height is represented in meters.

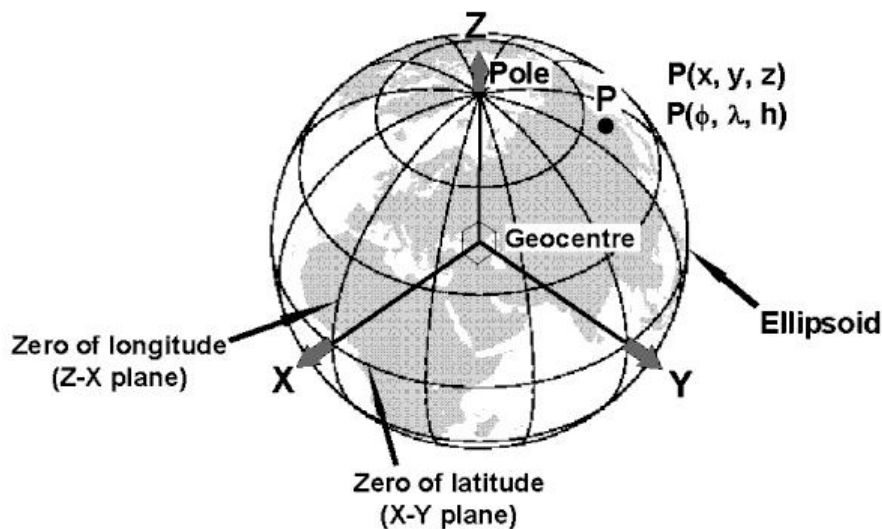

Figure 2.5: WGS 84 system, image taken from [EA415].

In Figure 2.5 it is possible to observe the Zero of Latitude on the Equator, and the zero on Longitude on Meridian of Greenwich.

2.5 RTCM messages

RTCM meaning is "Radio Technical Commission for Maritime Services" [RTC22], which is an independent international non-profit organization, whose mandate is to develop standards for radio communications and related applications, simplifying the procedures and standardizing the type of communication messages used, although its recommend to use

Global RTK Corrections

the RTCM standards they are not mandatory by any means, but instead advised to be guided and follow.

“The RTCM Special Committee (...) has examined the technical and institutional issues and formulated recommendations on the data format and content that are designed to support the most stringent applications in an efficient manner.” [fMS13]

RTCM messages can be used to send different types of messages, containing specific fields inside of them, two types of messages commonly used are OSR and SSR.

2.5.1 RTCM-OSR messages

OSR approach requires a two-way communication channel for each user and has high bandwidth requirements, which limit its scalability. It is expected that current mobile communication networks would not be able to sustain this level of communication were it to be adopted in mass, making RTK poorly suited for mass-market applications such as smartphones, IoT and the automotive industry [Age21].

Signal errors are introduced by several sources, including satellite orbit and clock errors, biases as well as ionospheric and tropospheric effects, the OSR messages corrects the positions using traditional RTK.

In short, the lump sum of these effects is observed by the reference stations and provided to the rover as range corrections for each supported combination of station, satellite, frequency and signal. Systems using this OSR messages in real-time [Geo15].

2.5.2 RTCM-SSR messages

As part of the RTCM messages there is the SSR type of messages used in the implementation of this method with the purpose of obtaining the corrected position.

3.1 A.5	1001-1039 1057-1068 4001-4095	State space representation (SSR; PPP) messages
---------	-------------------------------------	--

Table 2.1: RTCM SSR messages spectrum, table taken from [fMS13].

This corrections are for GPS constellation in the messages 1057 to 1062. Similar messages with different IDs can be found for other constellations: GLONASS (1063-1068), Galileo (1240-1245), QZSS (1246-1251) and BeiDou Navigation Satellite System (BDS) (1258-1263).

The goal of the SSR computation module is to compute the orbits and clocks corrections that are necessary for the RT-PPP method.

SSR services can in principle supply an unlimited number of users at the same time, making it ideally suited for future mass market applications as *e.g.* autonomous cars or drones. To sum things up, SSR messages send each corrections individually, clock corrections, orbit corrections, global ionosphere correction, among others, allowing a computation for a final solution without the need of reference stations.

2.6 NTRIP

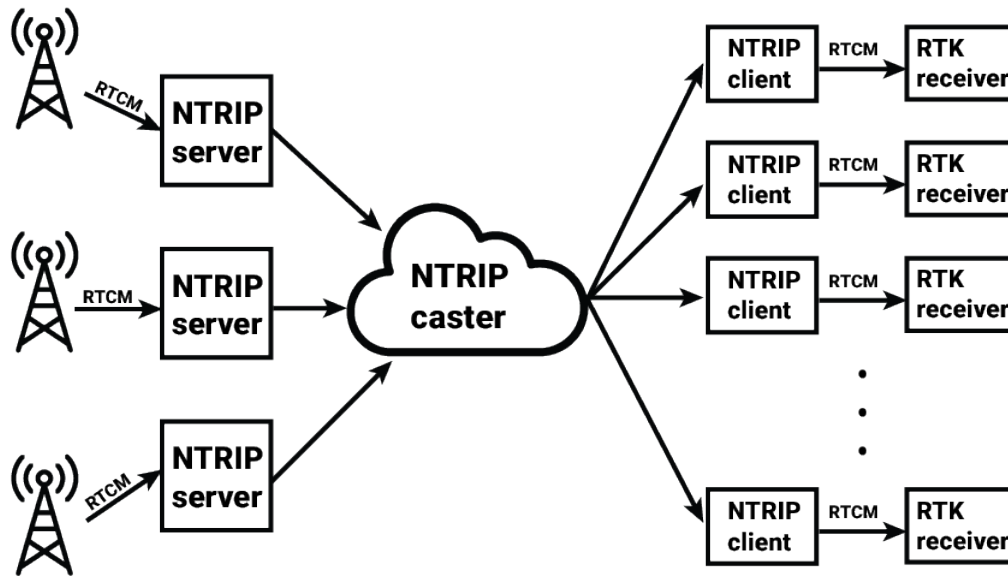

Figure 2.6: NTRIP network, image taken from [ard22].

NTRIP is regarded as one of the fundamental techniques for the streaming, management and dissemination of real time GNSS-data correction through the Internet via Transmission Control Protocol/Internet Protocol (TCP/IP) in order to operate in RTK mode, real-time. The components visible in Figure 2.6 of a NTRIP network are[WDG05]:

- NTRIP Sources, which generate streams at a specific location, usually a reference station generating RTCM messages in real-time, the vast majority of reference stations already have integrated NTRIP functionalities in the receptor;
- NTRIP Servers, which transfer the data from multiple sources in NTRIP supported format to the Caster;
- NTRIP Caster, the major stream-splitting and broadcasting system component, a program running on a server that streams the data to the clients in the network;
- NTRIP Clients, receiving data of desired sources from the Caster.

The main advantages of operating a NTRIP network are based on Hypertext Transfer Protocol (HTTP) as an application protocol layer on top of Transmission Control Protocol (TCP). Any data stream is transmitted exclusively through HTTP, eliminating many problems with firewalls [WDG05].

Other advantage over its previous radio setup method using Ultrahigh Frequency (UHF) is that less equipment is needed. Nowadays almost all data collectors, smartphones, and computers have the capability to connect to the Internet even in a field setting, through a Subscriber Identity Module (SIM) card. Mitigate the chance of radio interference and no limitation on communication range [ags22].

Global RTK Corrections

NTRIP uses RTCM messages for communicating in between the network, discussed in more detail in section 2.5.

2.7 Reference Stations

A permanent station or a Continuously Operating Reference Stations (CORS). The CORS network is a multi-purpose, multi-agency cooperative endeavor, combining the efforts of hundreds of government, academic, and private organizations. The stations are independently owned and operated [Suv22].

Permanent GNSS stations form the modern-day reference points for positioning and surveying.

There are also campaign stations where the main purpose is to survey a specific area for some time and after the objective was accomplished the station is removed.

The proposed method was implemented in some campaign stations in Azores to correct their position in real-time.

Global RTK Corrections

Chapter 3

State of the Art

3.1 Introduction

In this chapter, concepts related with the use of corrections to improve GNSS positions in real-time, normally known as RTK, are addressed, the fundamentals, the disadvantages and advantages, the networks established in Portugal to apply the RTK method of correction, and at last, the proposed method is presented and discussed.

3.2 Real-Time Kinematic

Real-Time Kinematic was first proposed in the mid-1980s by Dr. Benjamin Remondi [RBoo]. This method is based on the principle that the errors that affect the calculation of the absolute position in the GNSS are approximately uniform in the same region they are working.

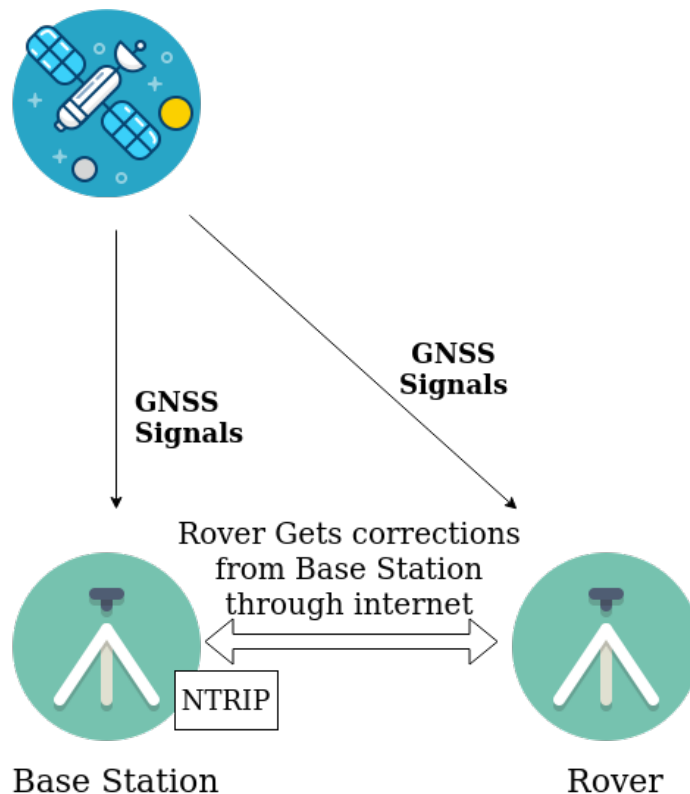

Figure 3.1: Concept of Real-Time Kinematic.

As shown in Figure 3.1, the RTK initial concept, also known currently as OSR, still the most used method nowadays, consists of a base station and a rover working together. The base station has a stationary receiver where the location is known and fixed,

this station computes its position by using the signals received from the GNSS satellites “based on the carrier phase measurement technique”. It then “compares this location to its known location to identify any errors and generate a correction signal” [Edw03].

This errors can be attributed to the effects of ionosphere, troposphere and orbits of GPS satellites, oscillators of satellites and receiver [Silo7].

Then the correction of the position is transmitted to the rover in real-time. This way the rover is able to use this correction to improve its own computed position, achieving centimetre level accuracy.

3.2.1 Applications of RTK

The method of RTK has many applications in a wide range of areas, for example in the use of surveying and register land changes, being one of the major uses of RTK, in order to urban planning, landscape construction or resources management, having large advantages in comparison to the traditional survey techniques [Xu12]. Also for structural health monitoring, alerting for sudden changes in the bridge deck, anticipating for possible catastrophes [GXD⁺05], as represented in Figure 3.2.

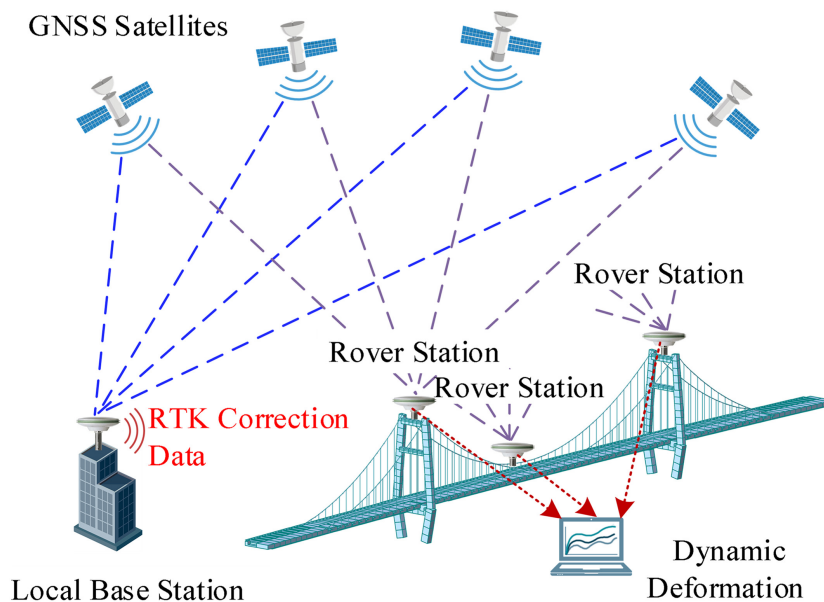

Figure 3.2: Monitoring of bridge using RTK, image taken from [GXD⁺05].

Other example of the use of RTK is correcting the position of drones on the flight, by receiving the RTCM messages and applying the corrections in real-time to compute the position of the drone in real-time [UPKK20].

3.2.2 Advantages of RTK

The use of the traditional RTK has its advantages, some of them are:

- RTK provides centimeter level positioning accuracy in real-time;

Global RTK Corrections

- RTK is based on the “Phase Measurement Technique” [BDVP⁺20] which is not affected by weather conditions;
- No need for inter-visibility;
- Autonomous RTK assisted landing, eliminating human errors caused in traditional surveying.

3.2.3 Disadvantages of RTK

After discussing some advantages of the traditional RTK, here are some of its disadvantages:

- Unavailable in some areas without base stations previously mounted, without nearby stations this method does not have good precision;
- GNSS outages can impact the system performance, without a permanent view to the satellites this method will have less precision in the position, specially in urban zones or with a lot of trees can be difficult to obtain signals from the satellites;
- High cost, the number of devices needed to operate a reliable dense network is expensive.

3.2.4 Regional networks

Corrections based on OSR corrections need regional networks to operate in RTK mode, Portugal has at disposal the SERVIR infrastructure, which was implemented in 2006 to facilitate land surveying with GNSS.

Global RTK Corrections

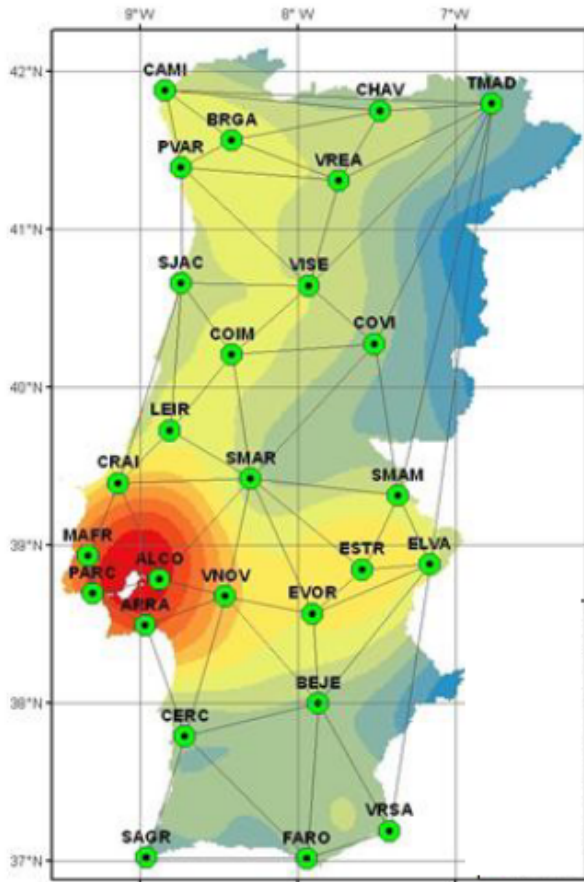

Figure 3.3: SERVIR and RENE network of stations in Portugal [dS16], [dT].

It is a network constituted by twenty-seven stations scattered in Portugal, as seen on Figure 3.3, left side, with the respective territorial density of the stations, the darker colours means a better coverage by the reference stations.

RENEP [dT] is another network, available by *Direção-Geral do Território (DGT)*, having stations in the mainland of Portugal, as shown in Figure 3.3, right side, but also on the islands, autonomous regions of Madeira and Azores, having a total of forty-six stations, getting a bigger coverage of the territory due to that reason.

Another organisations also have installed permanent stations in Portugal. One of them is Collaboratory for Geosciences (C4G) [C4G22] which is a research infrastructure of the national road map which headquarters are at Universidade da Beira Interior (UBI).

Recently, C4G has installed a network of permanent stations (see Figure 3.4) in São Jorge, Azores, in response to the seismic crises that started in March 2022. This network also

Global RTK Corrections

uses stations from the regional GNSS network, called Rede de Estações Permanentes Região Autónoma dos Açores (REPRAA), and from a collaboration between UBI and Instituto Português do Mar e da Atmosfera (IPMA), the national agency responsible for monitoring seismic crisis. One station is PAGU in Terceira Island, which is also sending a stream to JPL in a separate stream, which allowed us to compare the solutions computed by JPL with the ones estimated using the method implemented here.

The Azores seismic crises, probably caused by a potential volcanic event, brought an opportunity to test the method being implemented. Preliminary studies were carried out with the observations from these observations with the goal to implement in the future the automatic analysis of such networks.

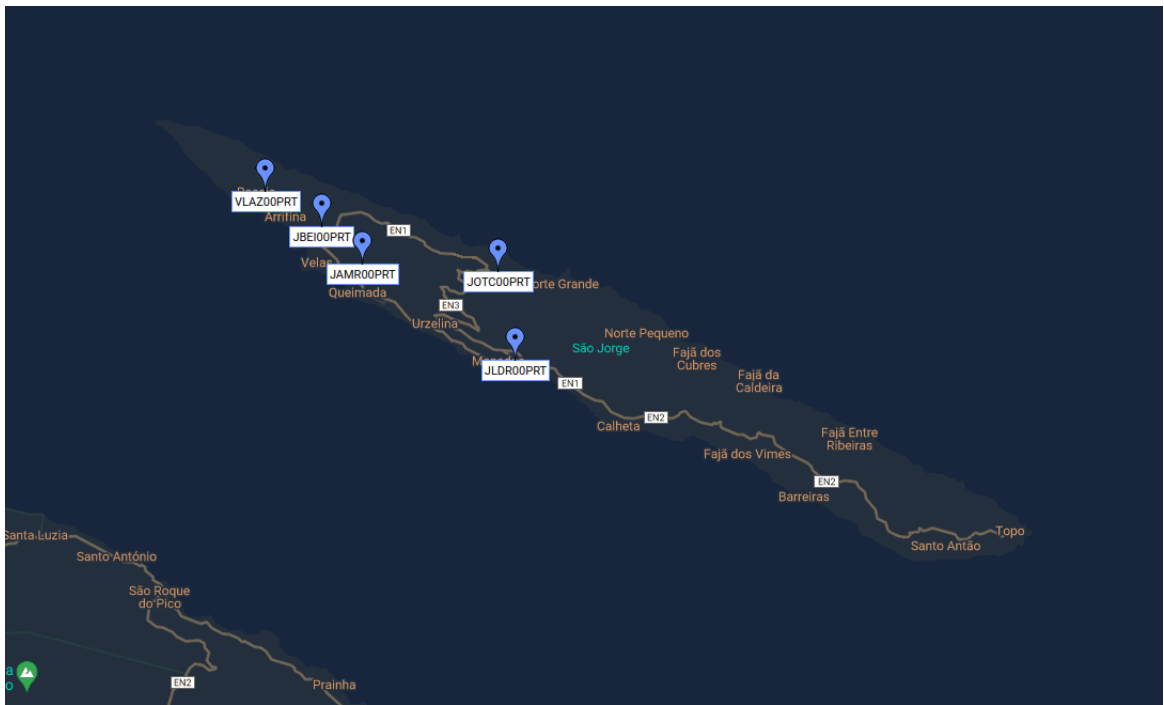

Figure 3.4: São Jorge Island and respective stations, image from [MIR22].

Figure 3.4 represents the stations operated by C4G in São Jorge Island.

3.3 Global SSR networks

Permanent stations, CORS are used as analysis infrastructure which process the real-time observations and compute epoch-wise orbit and clock products. These are formatted using RTCM SSR encoding software and transmitted to the NTRIP casters at the data centres.

Global RTK Corrections

3.3.2 IGS network

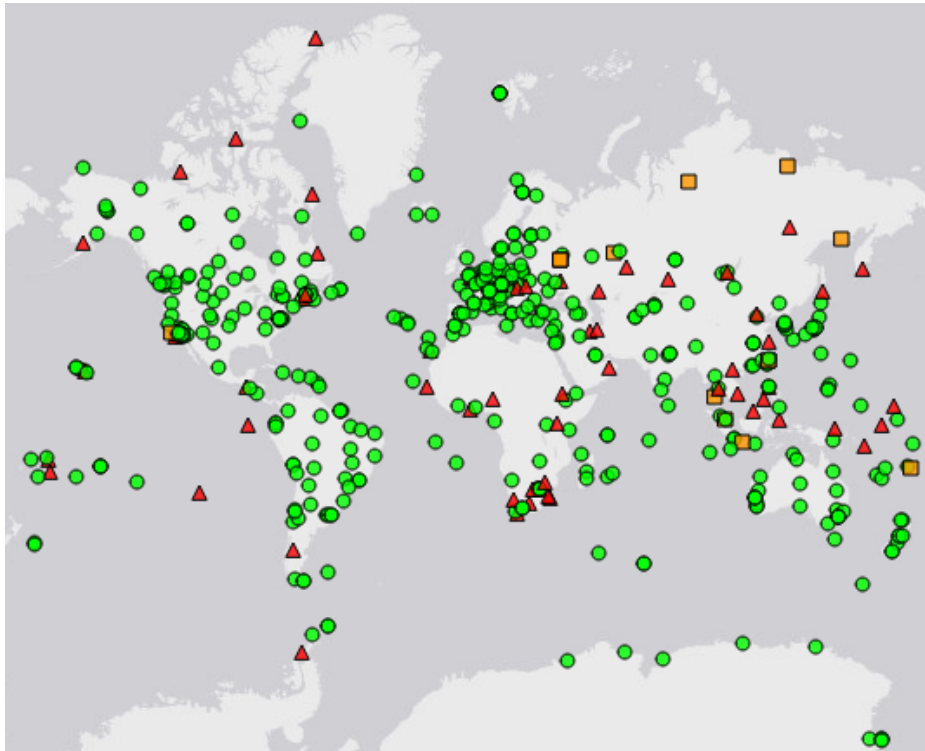

Figure 3.6: IGS network of stations in the World [IGS22b].

Real-time service is based on the IGS global infrastructure of network stations, Figure 3.6, data centres and analysis centres that provide world standard high-precision GNSS data products [IGS22c], being one of those products the SSR corrections.

3.3.3 Galileo High Accuracy Service

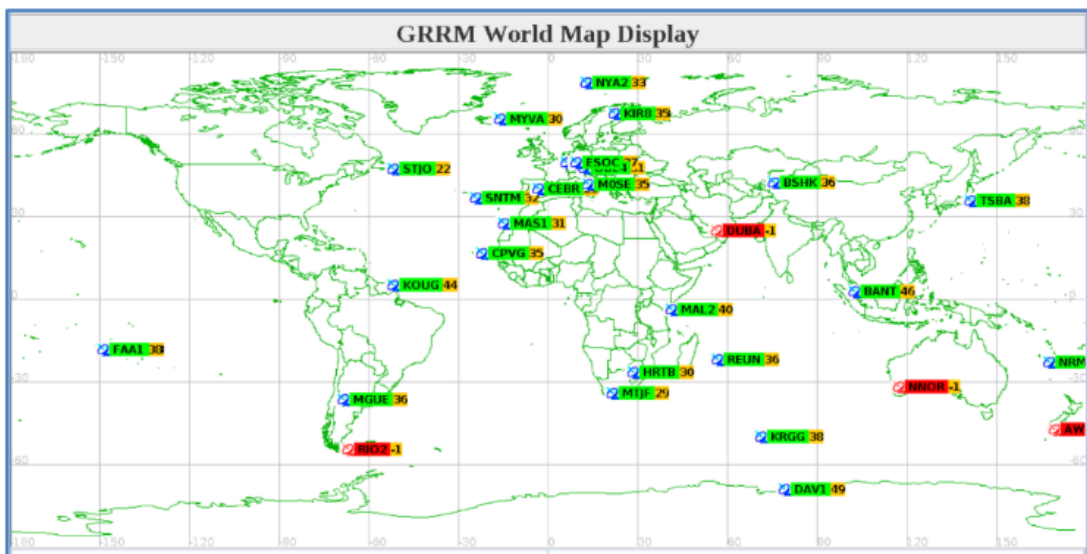

Figure 3.7: HAS network of stations in the World [DB21].

Galileo HAS will provide free of charge high-accuracy PPP corrections, by the Galileo E6-B signal data component and by terrestrial means, for Galileo and GPS (single and multi-frequency) to achieve real-time improved user positioning performances (positioning error of less than two decimetres in nominal conditions) [Age22]. This European-controlled service is based on Radio Technical Commission for Maritime Services - Compact State Space Representation (RTCM-CSSR) and is aimed at market applications (professional or commercial).

Dense Reference Receiver Network to achieve geometric diversity of the observations to provide stable service for the global service area, represented in Figure 3.7.

3.4 Comparative of OSR with SSR

RTCM standard has been widely accepted for OSR data to traditional RTK, the standardisation process using SSR for RT-PPP is ongoing. The future suggests the full adoption of SSR services.

Comparative of the message formats in Figure 3.8 and the parameters.

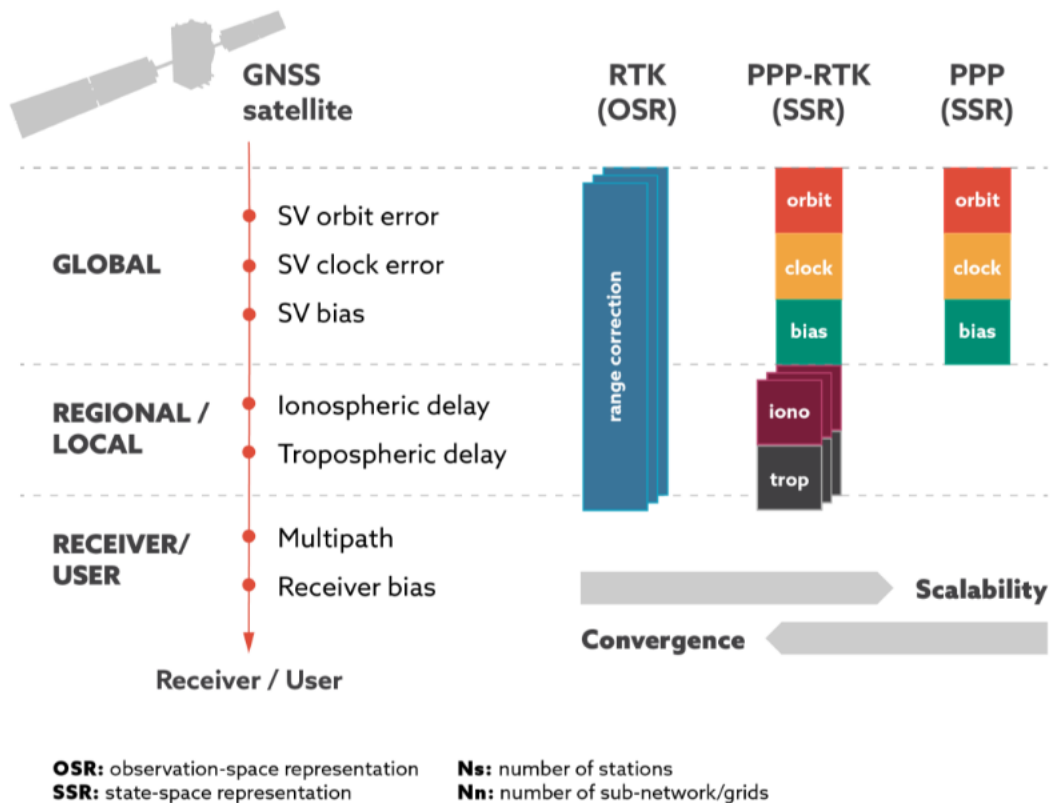

Figure 3.8: Message Format Comparison, image taken from [Age21].

The main advantage is that each user does not require a unique data stream with observations tailored for their location to be replaced with a single universal stream that can be used by all observers. This is a requirement if the technology is going to be adopted for the mass-market automotive industry for self-driving cars, since it is not practical to

Global RTK Corrections

OSR	SSR
Centimetric accuracy	Centimetric accuracy
Local Coverage	Global Coverage
Bi-lateral communication	Unilateral Communication
High bandwidth requirements	Low bandwidth required
Calculation of single-point corrections	Calculation of corrections over the entire coverage area
-	No 100% compatible hardware to date
-	Longer initialization time

Table 3.1: Comparison between SSR and OSR

provide every car with its own data stream [Eve18].

Table 3.1 compares the two types of messages [Ter20] directly.

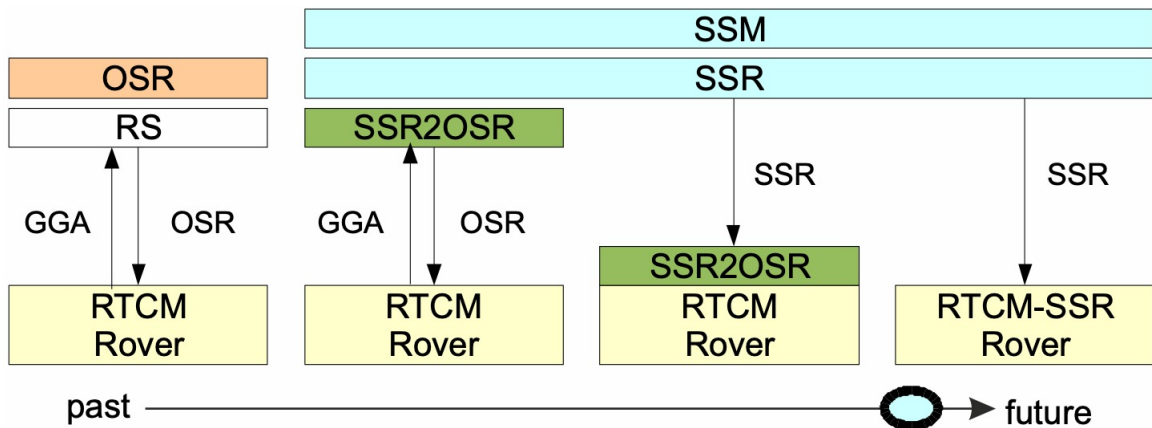

Figure 3.9: SSR and OSR implementation [Geo15].

Figure 3.9 represents a brief history of the implementation of the corrections by the receptors, legacy rovers that do not support SSR messages is necessary to convert SSR information to OSR. This conversion can also be performed at the rover site. With ongoing standardization and rover development, more and more rovers are inherently capable of SSR, making OSR obsolete.

On the other hand, SSR takes some time to initialize and stabilize the solution, while OSR is essentially instantaneous.

3.5 RT-PPP

RT-PPP as become an attractive alternative to RTK. It consists in a signal augmentation technique that removes GNSS system errors to provide high accuracy positioning using only a single receiver. PPP solutions rely on GNSS satellite clock and orbit corrections, generated from a network of global CORS.

The method used for calculating the corrected position was PPP, in this case RT-PPP.

PPP is a position method by GNSS that can provide centimeter accuracy solutions. It is possible thanks to the availability of precise products, for orbits and clocks, provided by the IGS.

It has been demonstrated that centimetre-level point positioning is achievable in post-processed, static receiver mode, and potentially also for kinematic applications [RJRG12], but the main focus have since shifted to real-time or near real-time solutions.

The main disadvantage in using this method of RT-PPP is the time required for solution convergence as demonstrated later. The method needs to estimate state parameters, such as the respective delays and ambiguities. However including application of SSR corrections for atmospheric parameters, such as ionospheric and tropospheric delays, have demonstrated improvements with convergence at the centimeter level in first fifteen minutes or even less [SMS⁺12].

3.6 IGS

The IGS has ensured open access, high-quality GNSS data products since 1994. Provides GNSS orbits, tracking data, and other high-quality GNSS data and data products on line in near real-time. These products enable access to the definitive global reference frame for scientific, educational, and commercial applications, a benefit to the public, and key support element for scientific advancements [IGS22a]. IGS also provides SSR streams for their users.

3.7 Conclusion

This chapter concludes the major methods related to the proposed method, being possible to learn and know how the previous methods function, focusing in the GNSS system and the RTK method for positioning and also the networks existing in Portugal to operate such methods, however the existing networks in Portugal only use RTK for positioning.

The different types of messages used for correcting the positions is presented with the discussion and comparison of both.

Chapter 4

Methods

4.1 Introduction

This chapter discusses the proposed method in detail, the schema and the hardware implemented, the materials used and the respective implementation of them.

4.2 Methods

Figure 4.1 represents the schema of the network and the interconnections in between them, the base stations send their positions via Internet to a caster and the Virtual Machine 2 uses that position and the SSR messages sent to the Tunnel machine and forwards it to port 25000, computing the solution and outputting it in the given port for each station. Afterwards the Virtual Machine 1 reads the output in that port and writes it to a file and process it for the intended format and stores it in the Network Attached Storage (NAS), that file location is shared with the web server GEODAC.

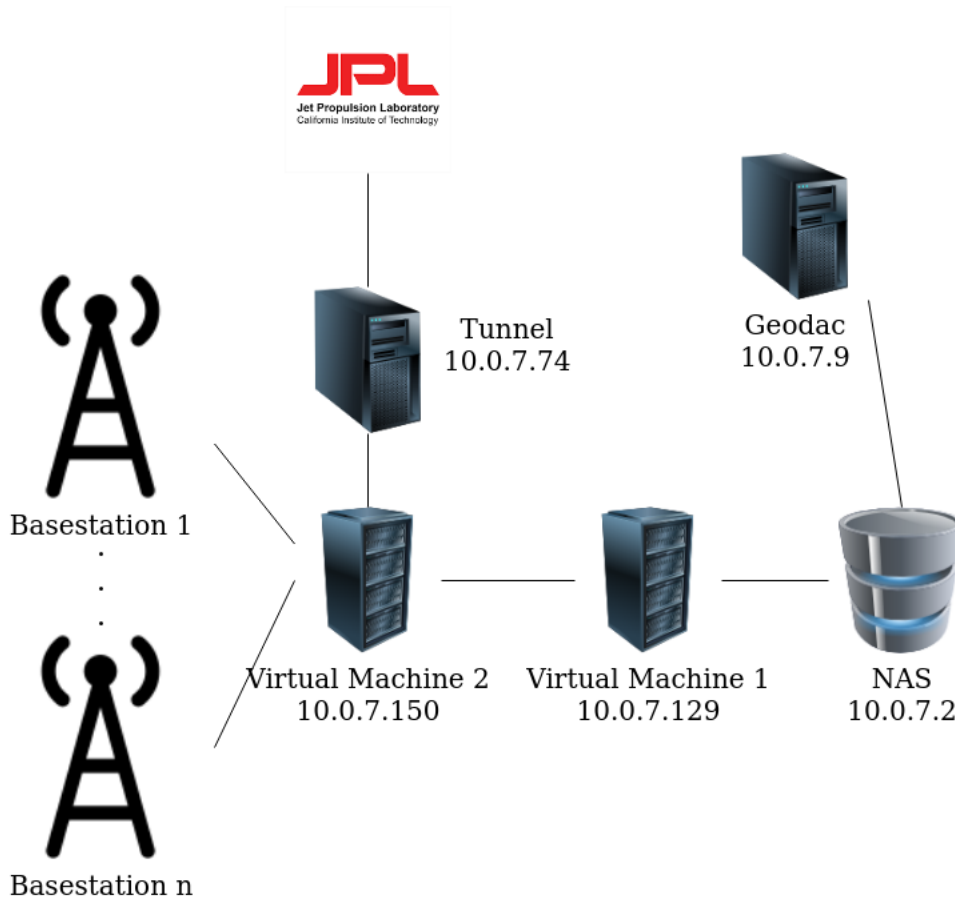

Figure 4.1: Implemented Network Schema.

4.3 Materials

In order to accomplish this work several tools were used for the final goal of obtaining the corrected positions in real-time.

4.3.1 SSR corrections

JPL supported this project by streaming in real-time SSR messages to SEGAL servers, and by offering support when questions appeared.

Global RTK Corrections

Table 1: Message Envelope

Field	Data Type	Size (bytes)	Description
Preamble	char	4 bytes	“\$JOC” 0x244A4F43
Message Version	uint16	2 bytes	A field identifying the type/version of the message.
Message Length	uint16	2 bytes	The length of the message in bytes
Variable Length Data		variable	The size of the data will be $9 + 2*c + 85*s$ bytes, where c is the number of constellations and s is the number of satellites
CRC		3 bytes	QualComm definition CRC-24Q (same as RTCM version 3) computed over the whole packet before the CRC

Table 4.1: SSR Message Envelope, image taken from [JPL17].

Figure 4.1 it is possible to identify the envelope fields of a SSR message being used by JPL, the preamble, used in network communications to synchronize transmission timing, for a first introduction and prepare the decoder for the beginning of the message. Afterwards the next field contains the message version, it follows the message length for the decoder to recognize the data length and decode it correctly, to end the envelope a Cyclical Redundancy Check (CRC) field is added with the purpose of error control. Error control coding provides the means to protect data from errors and involves essentially adding a certain amount of redundancy to the data in a controlled fashion [RG88]. Preserving the integrity of data in transmission in case of errors.

4.3.2 RTKLIB

RTKLIB [TA22] is a complete framework for GNSS related computations, and as such already supports SSR messages, decoding and computing them. It is also a open source program available in GitHub for everyone to use and make changes to the code if needed. The software RTKLIB has the possibilities to change the ambiguity resolution of the PPP method, ambiguity resolution is used for achieving the highest accuracy, provides improved estimates for user parameters.

Studies have demonstrated a 30% improvement in the longitude component, enhanced receiver clock stability estimates, and reduced errors in PPP-derived atmospheric delays. Precise Point Positioning with ambiguity resolution (PPP-AR) can also significantly improve the accuracy of short observation sessions, which is especially beneficial for field-work in many industries [Ban18].

The PPP-AR is based on a Kalman Filter process [LWL13]. The Kalman filter estimates the position taking into account the observations observed over time and a model describing the expected changes. Given more or less weight to the observations or the model gives different sensitivity to changes in the position. RTKLIB has three different options that handles differently these relations:

The **Fix and Hold** option has a short-circuited validation process. Fix and hold gives up

confidence in the solution in exchange for improvement in its accuracy.

In the **continuous** mode, the ambiguities are continuously estimated and resolved taking into account all the solutions previously computed.

The **instantaneous** mode, the integer ambiguity is estimated and resolved by epoch by epoch basis not taking into account previous epochs.

4.3.2.1 RTKNAVI

RTKNAVI is a tool available in RTKLIB, supporting real-time processing, allowing multiple types of input, such as NTRIP, TCP as server or client, Serial and File, allowing the same type of outputs but with different format options, ECEF coordinate system, Latitude/Longitude/Height, East/North/UpBaseline or National Marine Electronics Association (NMEA)0183, “a standard developed by the National Marine Electronics Association for interfacing marine electronic devices, and it has become a standard interface for GPS receivers whether they are used at sea, or in the air.” [Lan95]. The GUI of RTKNAVI is visible in Figure 4.2.

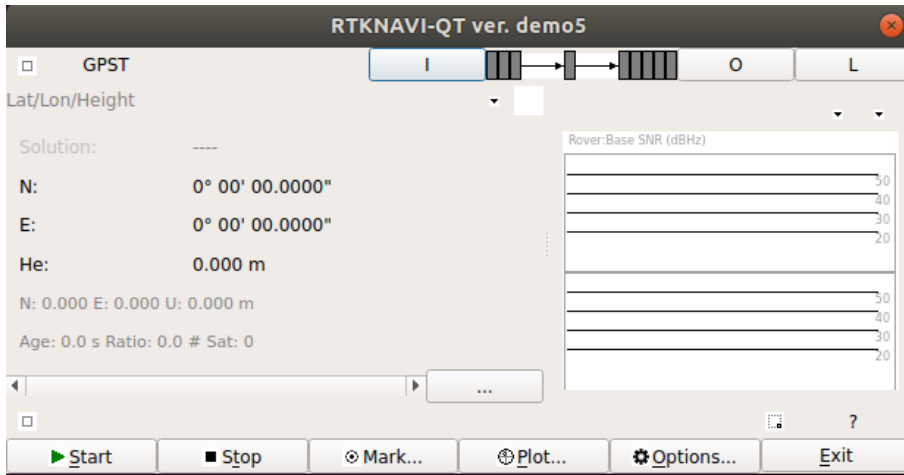

Figure 4.2: RTKNAVI GUI on the startup.

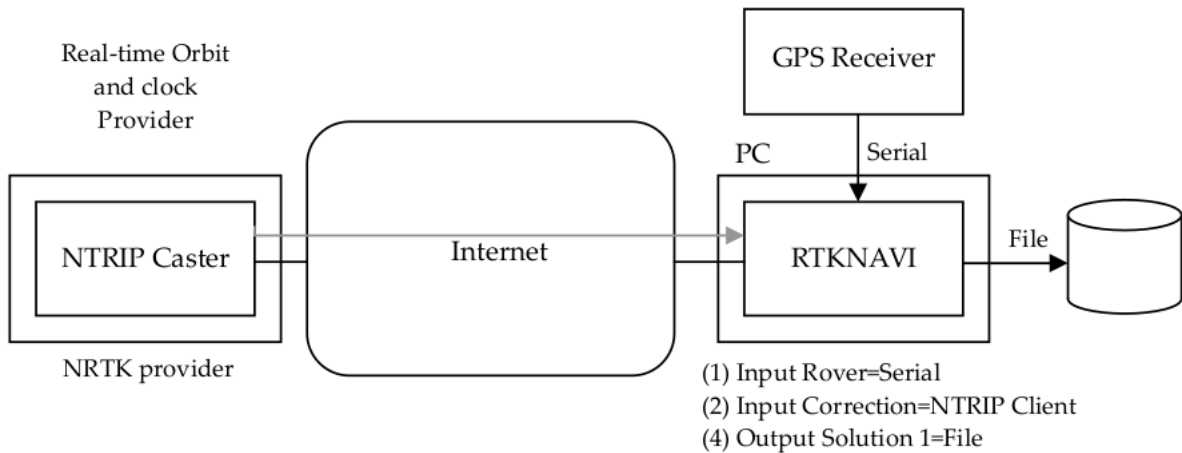

Figure 4.3: RT-PPP schema flow in RTKNAVI, schema from RTKLIB manual [Tak13].

Global RTK Corrections

Schema 4.3 represents the data flow of a typical RT-PPP in RTKNAVI, for this implementation the Orbit and clock messages will be received via TCP, the GPS receiver will transmit via NTRIP and the solution will be outputted in a given port or file in the machine in real-time.

4.3.2.2 RTKRCV

However RTKNAVI is the GUI software to obtain solutions in real-time, a command line program was necessary in order to automatize the implementation in case of shutdowns or any problem that could appear.

RTKRCV is a command line version of the real time positioning RTKNAVI. One of the options that offers is the `-s` option, starting a RTK server on program startup, other option is the `-o` option, allowing for a configuration file containing the parameters for the RTK server to be initialized, configurations such as type of processing, in this case PPP, the input methods and parameters, and the solutions output.

4.3.2.3 STR2STR

The program STR2STR functions as a communication server, inputs a data from a stream and outputs it in multiple streams with multiple possible formats. For this specific case a NTRIP input connection was used and the output on port 25000 was listening to possible requests from other machines to send them the corrections.

4.3.3 GNSS receivers

There are multiple brands of receivers available for setup of the GNSS stations. The ones used for this work were Trimble, and Septentrio.

Trimble NETR9 is a GNSS receiver, that is being used in PAGU station with firmware version 4.81



Figure 4.4: Trimble NETR9 GNSS receiver, image taken from [Aim22].

Figure 4.4 is an example of the receiver used in PAGU station.

The setup was implemented by reading and following the instructions of the Trimble manual for this configuration [TRI10].

Other of the receptor use is Septentrio PolaRx5 [Sep22] is a multi-frequency, multi-constellation GNSS reference receiver.



Figure 4.5: Septentrio PolaRx5, image taken from [Sep22].

The NTRIP configurations were implemented in order to receive them and also calculate the corrections with them, outputting the final solutions corrected. The setup was implemented by reading and following the instructions of the Septentrio manual for this configuration [Sep21].

4.3.4 Virtual Machine

Two virtual machines were used for the implementation of the method, with similar characteristics, 2 GB of Random Access Memory (RAM), running version 8.5 of Rocky Linux [Fou22] as the operative system, is a free open-source Operating System (OS), based on Red Hat Enterprise Linux (RHEL).

4.3.5 GEODAC

GEODAC is a desktop type machine equipped with Intel Pentium Dual CPU E2200 processors with 4 Gigabyte (GB) of RAM running Ubuntu 10.10.

One of the main purposes of this machine is to serve as a web server.
server

4.3.6 Tunnel

Tunnel is a virtual machine with the main task to be used as a tunnel for the communications from the Internet to the machines inside, being used to receive the SSR messages sent from JPL to the tunnel machine and mirroring them to anyone in port 25000.

4.3.7 NetCat

NetCat (NCAT) is a “feature-packed networking utility which reads and writes data across networks from the command line” [Ker22], was used for listening to a pre-determined

Global RTK Corrections

port in a given machine, was implemented in order to read the corrections in real-time and process them.

4.3.8 Tenex C Shell

Tenex C Shell (TCSH) is a command language interpreter usable both as an interactive login shell and a shell script command. It is “an enhanced version of C shell (CSH), is almost entirely upward compatible with CSH.”

“A shell is a command interpreter. You type commands into a shell, and the shell passes them to the computer for execution. UNIX systems usually provide several shell choices.” [DuB95]

One of the shell choices include TCSH, “has its origins in Berkeley UNIX, is particularly suited for interactive use. It offers many features, including an ability to recall and modify previous commands, a facility for creating command short-cuts, shorthand notation for path names to home directories, and job control.” [DuB95]

Available as an open source interpreter in GitHub [Org22c].

This interpreter was used in multiple scripts, due to its simplicity, familiarity and quickness.

4.3.9 Python

Another programming language used was Python. “Python combines remarkable power with very clear syntax. It has modules, classes, exceptions, very high level dynamic data types, and dynamic typing. There are interfaces to many system calls and libraries” [Org22b]. The extensive availability of libraries was the main reason in choosing Python, in this implementation version 3.7.6 was used [Org22a].

4.3.10 Portal

The laboratory of SEGAL [SEG22b] has a portal allowing for users around the globe to access, download and upload information related to GNSS. This portal is installed and managed by the GEODAC machine, section 4.3.5.

4.3.11 Statistics

The statistics used to compare the methods were the standard deviation and arithmetic mean. The standard deviation is calculated by the following formula:

$$s^2 = \sqrt{\sum_{i=1}^n (y_i - \bar{y})^2}. \quad (4.1)$$

The standard deviation 4.1 is a measure of how spread out the numbers are. A large standard deviation indicates that the data is spread out, a small standard deviation indicates

that the data is clustered closely around the mean.

Listing 4.1 Command used for receiving and disseminate the SSR messages.

```
...
str2str -in ntrip://JPL:ntrip@64.22.149.xx:5555/JPL01 -out tcpsvr://:25000 -f 30
...
```

The command 4.1 is used in the Tunnel machine, section 4.3.6, that receives the stream of SSR messages from JPL and broadcasts it to multiple users that connect to tunnel in port 25000 using a TCP/IP protocol.

Listing 4.2 Excerpt of function used to decode a SSR message.

```
...
with open("SSR_file", 'rb') as f:
    while True:
        s = f.read(10000)
        # Find preamble
        index = s.find(b'\x24\x4a\x4f\x43')
        print(index)
        if( index != -1 ):

            c = s[index+4:index+6]
            print("Message Version:")
            a = c.decode('unicode-escape').encode('ISO-8859-1')
            i = int.from_bytes(a, byteorder='big', signed=False)
            print(i)

            c = s[index+6:index+8]
            print("Message Length:")
            a = c.decode('unicode-escape').encode('ISO-8859-1')
            i = int.from_bytes(a, byteorder='big', signed=False)
            print(i)

            c = s[index+8:index+12]
            print("Epoch:")
            a = c.decode('unicode-escape').encode('ISO-8859-1')
            i = int.from_bytes(a, byteorder='big', signed=False)
            print(i)

            c = s[index+12:index+14]
            print("Flags:")
            a = c.decode('unicode-escape').encode('ISO-8859-1')
            i = int.from_bytes(a, byteorder='big', signed=False)
            print(i)

            c = s[index+14:index+15]
            c = str(c, 'utf-8')
            print("Goc:")
            print(c)

            c = s[index+15:index+17]
            print("Server Identifier:")
            a = c.decode('unicode-escape').encode('ISO-8859-1')
            i = int.from_bytes(a, byteorder='big', signed=False)
            print(i)

            c = s[index+17:index+21]
            print("Source1 Identifier:")
            a = c.decode('unicode-escape').encode('ISO-8859-1')
            i = int.from_bytes(a, byteorder='big', signed=False)
            print(i)
...
```

Listing 4.2 represents a excerpt of the listing used to decode a SSR message in binary

Global RTK Corrections

format to readable text, starting by opening the file and finding the preamble pre-defined every start of SSR message, in order to start decoding the rest of the message.

4.4 Implementation

The correction method of SSR was implemented with the materials described in section 4.3. The implementation started with getting the virtual machine listen in a certain port to read the data in real-time and store it in a given location. Each station gets its own port and store location.

The process continues to be executed in the background as observed in the listing 4.3.

Listing 4.3 Function used to listen the ports for the corrections.

```
#!/bin/tcsh
#
echo "Starting ncat for stations"

# Check if its already running or not
if (`ps aux | grep "ncat -k -l 2102" | wc -l` < 2) then
    echo "VLAZ initiated"
    ncat -k -l 2102 > /ui/uib/PTAC/realtime/data/VLAZ/VLAZ_untreated.pos &
endif

# Check if its already running or not
if (`ps aux | grep "ncat -k -l 2103" | wc -l` < 2) then
    echo "QEMD initiated"
    ncat -k -l 2103 > /ui/uib/PTAC/realtime/data/QEMD/QEMD_untreated.pos &
endif

# Check if its already running or not
if (`ps aux | grep "ncat -k -l 2104" | wc -l` < 2) then
    echo "JBEI initiated"
    ncat -k -l 2104 > /ui/uib/PTAC/realtime/data/JBEI/JBEI_untreated.pos &
endif
...
echo "Finished..."
```

Other script was used to call the individual scripts to read the solutions of each station in the listing 4.4.

Listing 4.4 Function used to start reading the data.

```
#!/bin/tcsh
#
echo "Starting"
/ui/uib/PTAC/realtime/scripts/jbei_read_data.sh &
/ui/uib/PTAC/realtime/scripts/qemd_read_data.sh &
/ui/uib/PTAC/realtime/scripts/vlaz_read_data.sh &
/ui/uib/PTAC/realtime/scripts/jotc_read_data.sh &
/ui/uib/PTAC/realtime/scripts/jldr_read_data.sh &
/ui/uib/PTAC/realtime/scripts/jmar_read_data.sh &
echo "End"
```

After the script to read was called its function is to read the output of the NCAT in the respective position and treat it in the desire output and change it to the correct location in order to be read and presented in the website, represented in the listing 4.5.

Listing 4.5 Function used to read and process the solutions.

```
#!/bin/tcsh
#
# Check if is already running
if (`ps aux | grep "vlaz_read_data.sh" | wc -l` > 3) then
    echo "Already running ... stopping"
    exit 1
endif

# Obtain last line NCAT output to initialize the first time
set first_line = `tail -1 /opt/realtime/data/VLAZ/VLAZ_untreated.pos`

while(1)
    # Get last line
    set line = `tail -1 /opt/realtime/data/VLAZ/VLAZ_untreated.pos`
    # Compare the lines to check for new solution output
    if ("`$line`" != "`$first_line`") then
        # Split all line on space
        set list = ($first_line:as/ / /)

        # Create file with the know XYZ positions of VLAZ
        echo "YYYY/MM/DD HH:MM:SS 4389825.616 -2358297.798 3968260.177 0.0 0.0 0.0
0.0 0.0 0.0" > vlaz.txt

        # Transform XYZ coordinates to LLH
        set xyz = `opt/realtime/scripts/llh2xyz $list[3] $list[4] $list[5}`
        set x_y_z = ($xyz:as/ / /)
        echo "$list[1] $list[2] $x_y_z[1] $x_y_z[2] $x_y_z[3] $list[8] $list[9]
$list[10] $list[11] $list[12] $list[13]" >> vlaz.txt

        # Compute the ENU displacement using the obtained solution and the know position
        set ENU = `python3 /opt/realtime/scripts/compute_enu.py vlaz.txt`

        # Split the results
        set E_N_U = ($ENU:as/ / /)

        # Update first_line
        set first_line = `echo "`$line`"``
        set list = ($first_line:as/ / /)
        set line_position = "vlaz $list[1] $list[2] $E_N_U[1] $E_N_U[2] $E_N_U[3]
$list[1] $list[2] $list[3] $list[4] $list[5]"

        # Store the line
        echo "`$line`_position > /opt/realtime/data/VLAZ/VLAZ_treated.pos

    endif
endwhile
```

A program written in FORTRAN and was used in the method to convert Latitude, Longitude and Height coordinates to XYZ [Feroo].

After a full day of obtaining the solutions it is necessary to divide the files by order of the date, that is the function of the listing 4.6, stops the NCAT from writing on the file for a few moments and moves the files to a location appropriate with the respective date on the name of the file.

The following listing 4.7 contains the function used to compute the ENU displacement between observations.

```
realtime > data > JBEL > Old_data > JBEL_20220401.pos
1 2022/04/01 14:29:31.000 38.701503338 -28.209738543 385.6033 6 8 0.0014 0.0018 0.0027 -0.0003 0.0001 -0.0010 0.00 0.00
2 2022/04/01 14:29:31.000 38.719031962 -28.245537169 369.6983 6 8 0.0014 0.0021 0.0029 -0.0005 0.0007 -0.0008 0.00 0.00
3 2022/04/01 14:29:32.000 38.719031962 -28.245537169 369.6983 6 8 0.0014 0.0021 0.0029 -0.0005 0.0007 -0.0008 0.00 0.00
4 2022/04/01 14:29:32.000 38.701503338 -28.209738543 385.6033 6 8 0.0014 0.0018 0.0027 -0.0003 0.0001 -0.0010 0.00 0.00
5 2022/04/01 14:29:33.000 38.701503338 -28.209738543 385.6033 6 8 0.0014 0.0018 0.0027 -0.0003 0.0001 -0.0010 0.00 0.00
6 2022/04/01 14:29:33.000 38.719031962 -28.245537168 369.6983 6 8 0.0014 0.0021 0.0029 -0.0005 0.0007 -0.0008 0.00 0.00
```

Figure 4.6: Example of an output file from a station.

Global RTK Corrections

Listing 4.6 Function used to store stations data.

```
#!/bin/tcsh
#

pkill -f ncat

set date = `date --date="yesterday" +%Y/%m/%d`

mv /opt/realtime/data/QEMD/QEMD_untreated.pos /opt/realtime/data/QEMD/Old_data/QEMD_{$date}.pos
cat /opt/realtime/data/QEMD/Old_data/QEMD_{$date}.pos | grep `date +%Y/%m/%d`
> /opt/realtime/data/QEMD/QEMD_untreated.pos

mv /opt/realtime/data/VLAZ/VLAZ_untreated.pos /opt/realtime/data/VLAZ/Old_data/VLAZ_{$date}.pos
cat /opt/realtime/data/VLAZ/Old_data/VLAZ_{$date}.pos | grep `date +%Y/%m/%d`
> /opt/realtime/data/VLAZ/VLAZ_untreated.pos

...
```

Listing 4.7 Read a file and compute the weighted mean of the 3 coordinates.

```
#!/usr/bin/env python3
#

...

#####
# Main program
#####

if len(sys.argv)==1:
    print('usage compute_mean.py solfile')
    sys.exit()
else:
    [t,A,y,C,xyz0,L] = read_sol_file(sys.argv[1])

#--- Least squares
Cx = inv(A.T @ inv(C) @ A)
x = Cx @ A.T @ inv(C) @ y

...

print('{0:8.6f} {1:8.6f} {2:8.6f} {3:8.6f} {4:8.6f} {5:8.6f} {6:e} {7:e} {8:e}'.format(x[0,0],x[1,0],
x[2,0], math.sqrt(Cx[0,0]), math.sqrt(Cx[1,1]), math.sqrt(Cx[2,2]), Cx[0,1], Cx[0,2], Cx[1,2]))
```

Figure 4.6 displays an example of a stored file for the station JBEI, the first two columns represent the date and time of the solution, the other three the Latitude, Longitude in degrees and the Height in meters, the output can be converted to the Cartesian coordinates, the quality of the satellites and the number of satellites at the moment sending signals, the next six columns represent the standard deviations in the north, east, up in meters and the standard deviation of the means square root of the absolute value of NE, EU and UN means square root of the absolute matrix.

The fourteen column represents the time difference between the observation data epochs of the rover receiver and the base station in seconds.

The last column is the ratio factor, meaning the ratio of the squared sum of the residuals with the second best integer vector to with the best integer vector.

Listing 4.8 was implemented with the objective of creating the graphs previously presented using the system of coordinates XYZ.

Listing 4.9 was implemented to obtain the difference between the solutions from JPL to the proposed method and plot them in a graph.

Listing 4.8 Function used to create the graphs.

```

...
import matplotlib.pyplot as plt
import numpy as np

# PAGU XYZ coordinates
X_0 = 4429718.335
Y_0 = -2275036.395
Z_0 = 3972396.943

# Read file and store in arrays the data
data = np.genfromtxt("Pagu_file", delimiter=" ", names=["x","y","z"])

# Initialize array
XX = 0
YY = 0
ZZ = 0

# Create array with the number of solutions
t = np.arange(0.0, len(data), 1)

# Calculate for each i the result between solution obtained with the coordinates known
for i in range(1, len(data)):
    XX = np.append(XX, (data['x'][i] - X_0))
    YY = np.append(YY, (data['y'][i] - Y_0))
    ZZ = np.append(ZZ, (data['z'][i] - Z_0))

# Create graph
fig, ax = plt.subplots()

# Add labels
ax.plot(t, XX, label="X")
ax.plot(t, YY, label="Y")
ax.plot(t, ZZ, label="Z")

plt.axhline(y=0.0, color='r', linestyle='-')

# Name graph and variables
ax.set(xlabel='Displacement', ylabel='Observations', title='PAGU PPP')
ax.grid()

# Scale of the Y axis set to daily
plt.xticks(np.arange(min(t), max(t)+1, 86400))

# Add legend to graph and present it
plt.legend()
plt.show()
...

```

Global RTK Corrections

Listing 4.9 Function used to create the graphs making the comparison ENU.

```
# Read file and store in arrays the data
data = np.genfromtxt("Pagu_file", delimiter=" ", names=["x","y","z"])
data2 = np.genfromtxt("Pagu_file_2", delimiter=" ", names=["x","y","z"])

matrix = []
matrix2 = []

# Initialize arrays
XX = 0
YY = 0
ZZ = 0

# If the solutions are in LLH system
for i in range(1, len(data)-1):
    matrix.append(pm.ecef2enuv(matrix2[i][0]-4429718.335, matrix2[i][1]-(-2275036.395),
    matrix2[i][2]-3972396.943, X_0 , Y_0 , Z_0))

# If the solutions are in XYZ system, solutions of first file, compute ENU
for i in range(1, len(data)):
    matrix.append(pm.ecef2enuv(data['x'][i]-4429718.335, data['y'][i]-(-2275036.395),
    data['z'][i]-3972396.943, X_0 , Y_0 , Z_0))

# If the solutions are in XYZ system, solutions of second file, compute ENU
for i in range(1, len(data)):
    matrix.append(pm.ecef2enuv(data['x'][i]-4429718.335, data['y'][i]-(-2275036.395),
    data['z'][i]-3972396.943, X_0 , Y_0 , Z_0))

# Create array with the number of solutions
t = np.arange(0.0, len(data), 1)

# Calculate for each index the difference between solutions
for i in range(0, min(len(data), len(data2))-1):
    XXf = np.append(XXf, (matrix[i][0]-matrix2[i][0]))
    YYf = np.append(YYf, (matrix[i][1]-matrix2[i][1]))
    ZZf = np.append(ZZf, (matrix[i][2]-matrix2[i][2]))

# Create graph
fig, ax = plt.subplots()
...

```

Chapter 5

Results and Discussion

5.1 Introduction

This chapter addresses the respective results following a discussion of them, ending with a comparison in between methods used in this dissertation.

5.2 Results

The following results were obtained used the proposed method in comparison with the JPL solutions.

An experiment that was made using the permanent station located in UBI named SUBI, the connection was used for a movable Rover, the setup is demonstrated in Figures 5.1, 5.2, where the green antenna is the SUBI one and the gray is the Rover.

The main goal with this experiment was to analyze the solutions obtained after changes to the original positioning were made, for example in the height, and check if the PPP method would detect that and how long would it take to update the solution.



Figure 5.1: Movable Rover used.



Figure 5.2: Movable Rover used.

The three type of options for the ambiguity resolution were implemented independently but at the same time to evaluate and compare the methods to identify the better one. The experiment consisted in setting up the Rover and let stabilize the solution and then move the Rover vertically and horizontally to see the changes in the solutions for each method.

The reference values used were taken from SUBI station, although they are not the same they are very close to it, and the main goal was to check for jumps in the solutions.

5.2.1 Fix and Hold

Graph obtained for the Fix and Hold option in Figure 5.3, it is possible to detect jumps when the Rover moved. The solutions took around two seconds to adjust to the new positions, visible around observation number 13000.

The difference is represented in meters and the observations in seconds for all the graphs.

Global RTK Corrections

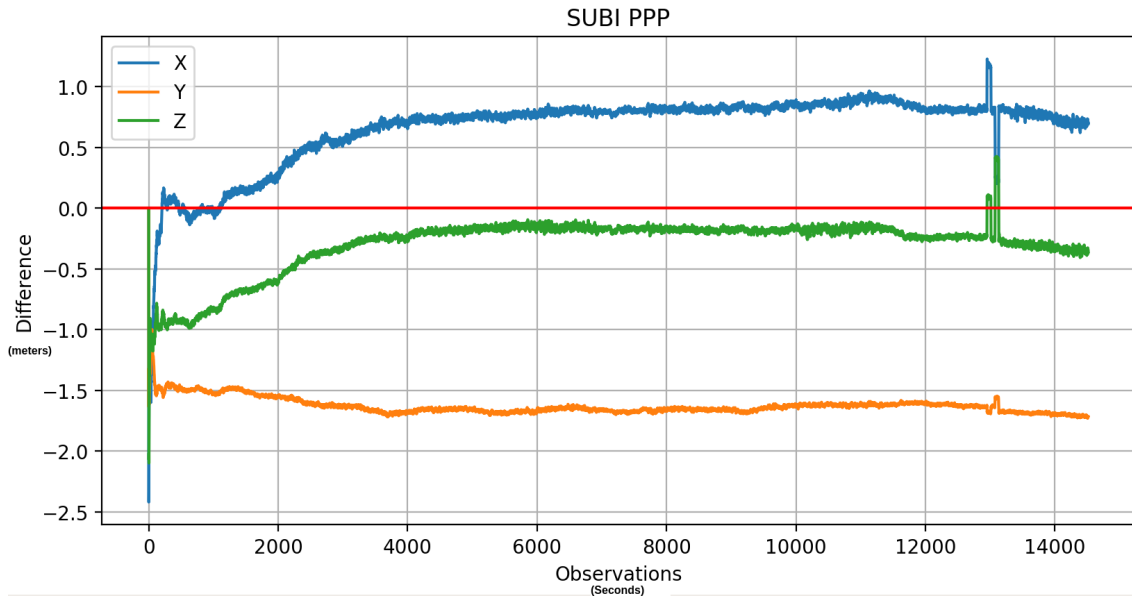

Figure 5.3: Fix and Hold experiment.

From this graph is possible to conclude that the Fix and Hold method detects the movement on the Rover.

5.2.2 Continuous

The graph obtained for the continuous option, in Figure 5.4 is not possible to detect jumps when the Rover moved.

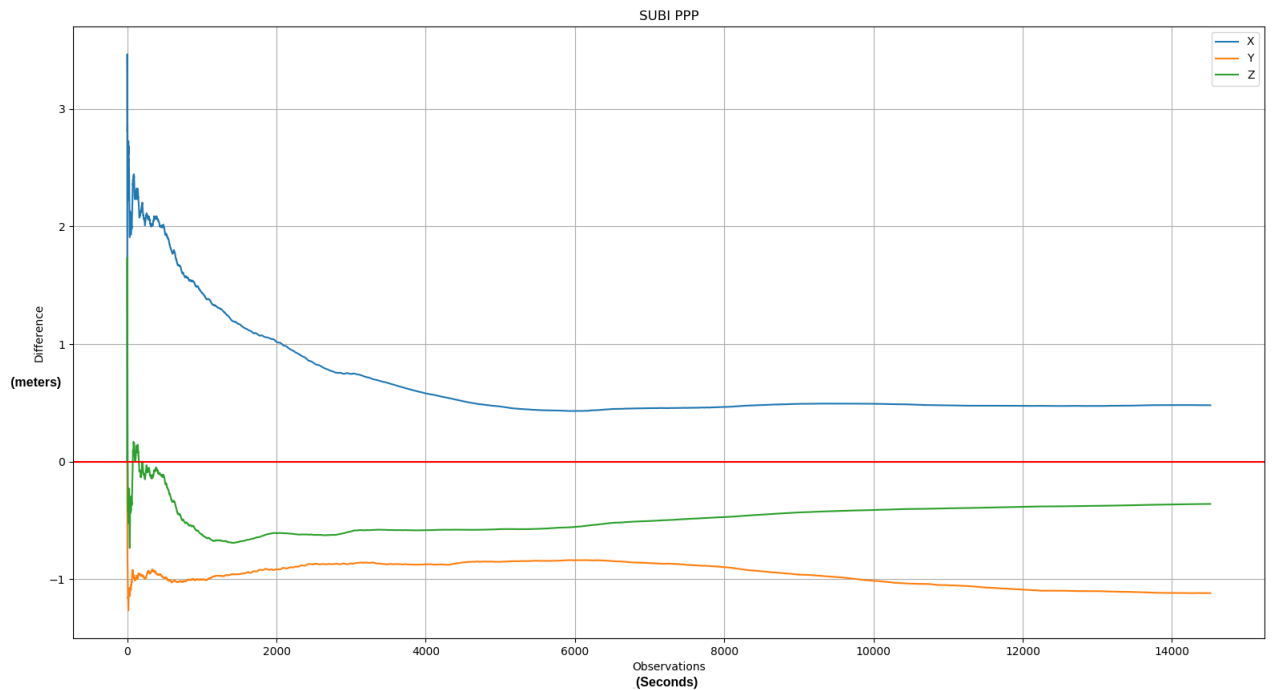

Figure 5.4: Continuous experiment.

From this graph is possible to conclude that the Continuous method does not detect the

movement on the Rover.

5.2.3 Instantaneous

The graph obtained for the continuous option, in Figure 5.5 is possible to detect jumps when the Rover moved. The solutions took around two seconds to adjust to the new positions.

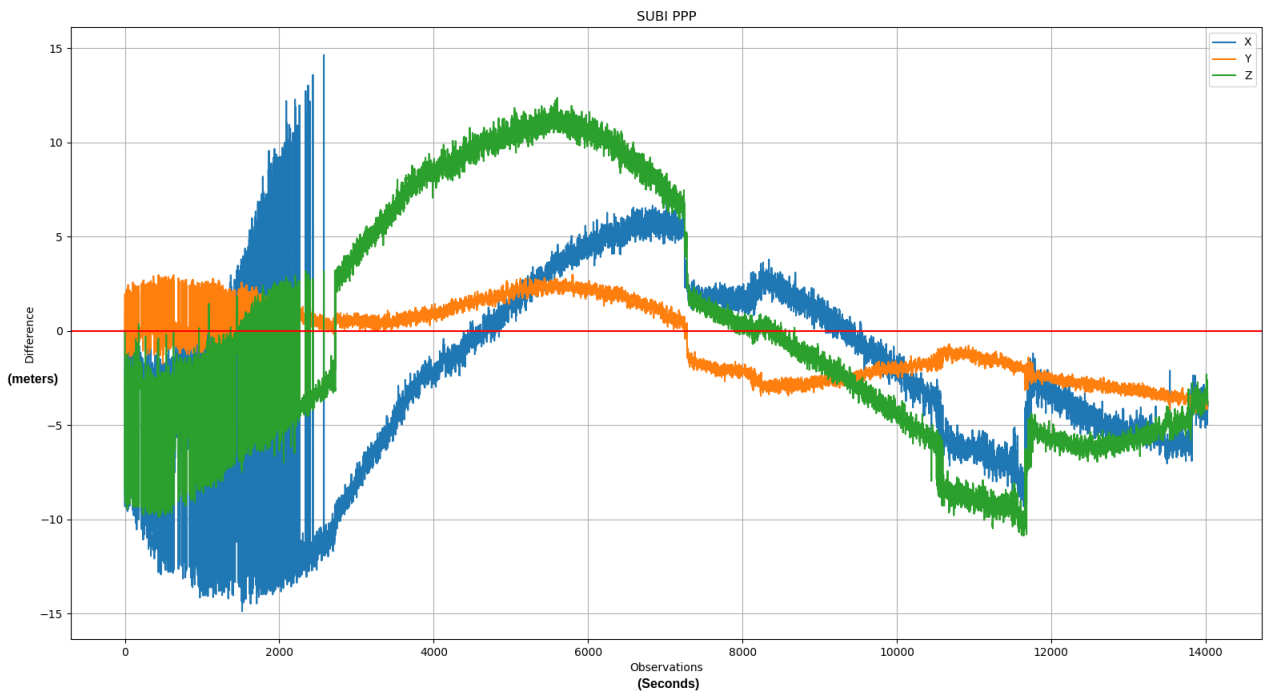

Figure 5.5: Instantaneous experiment.

From this graph is possible to conclude that the Instantaneous method has too much noise in order to extract significant information from it.

5.2.4 Height measurement

After the first experiment was made, and subsequently knowing that the best option is the Fix and Hold method to monitor changes, a similar experiment was made but focusing on the height component, where the height of the Rover was changed.

Inspecting only the height of the Rover it is possible to detect the increase in height from 1.52 meters in Figure 5.6, to 2 meters in Figure 5.7 around fifty centimeters in the height increase and going to 1.50 meters to see the accuracy of the final position.

Global RTK Corrections



Figure 5.6: 1.52 meter height of the Rover.



Figure 5.7: 2 meter height of the Rover.

The height difference can be observed in the graph 5.8, the increase and the subsequent

decrease.

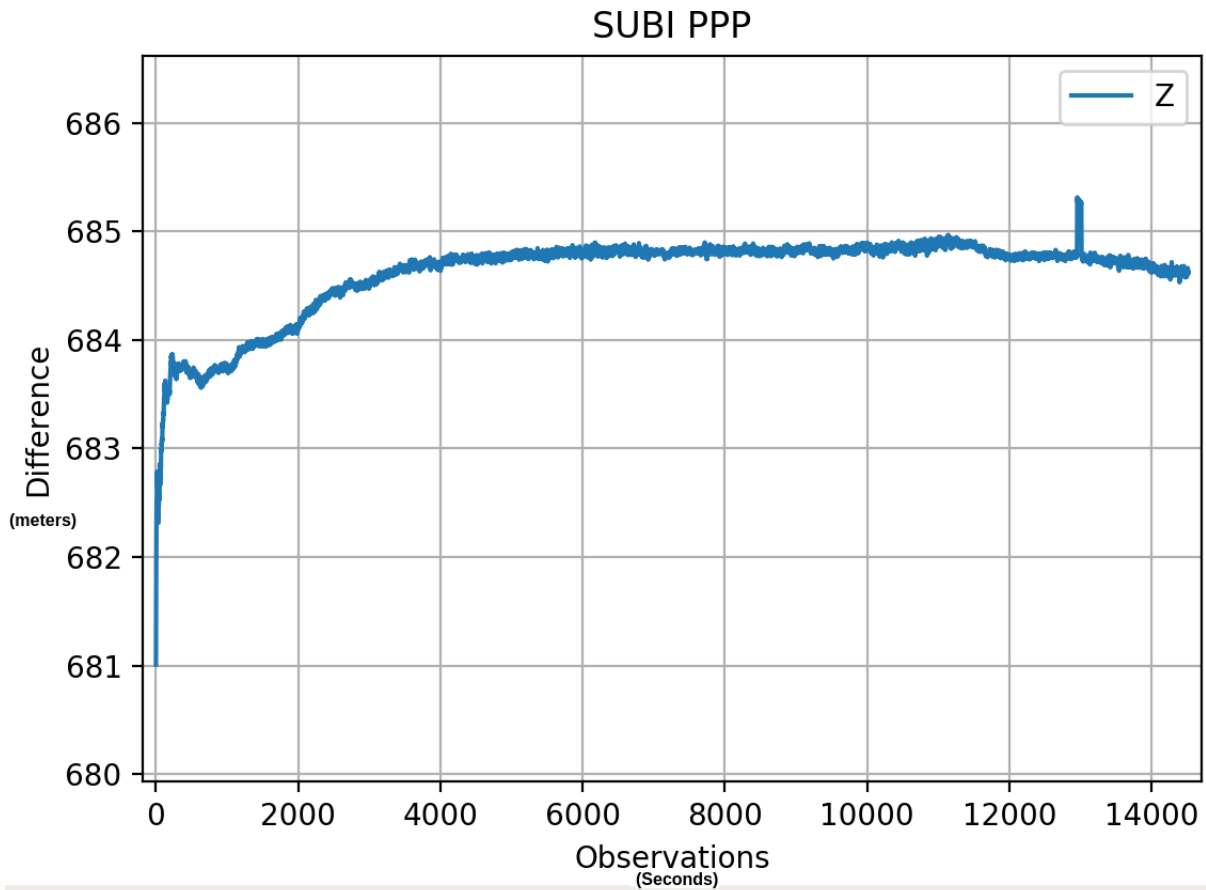

Figure 5.8: PPP Height measurement.

The height graph 5.9 zoomed in to observe the solutions in greater detail. It is possible to observe the 48 centimeters increase and the 50 centimeter decrease.

Global RTK Corrections

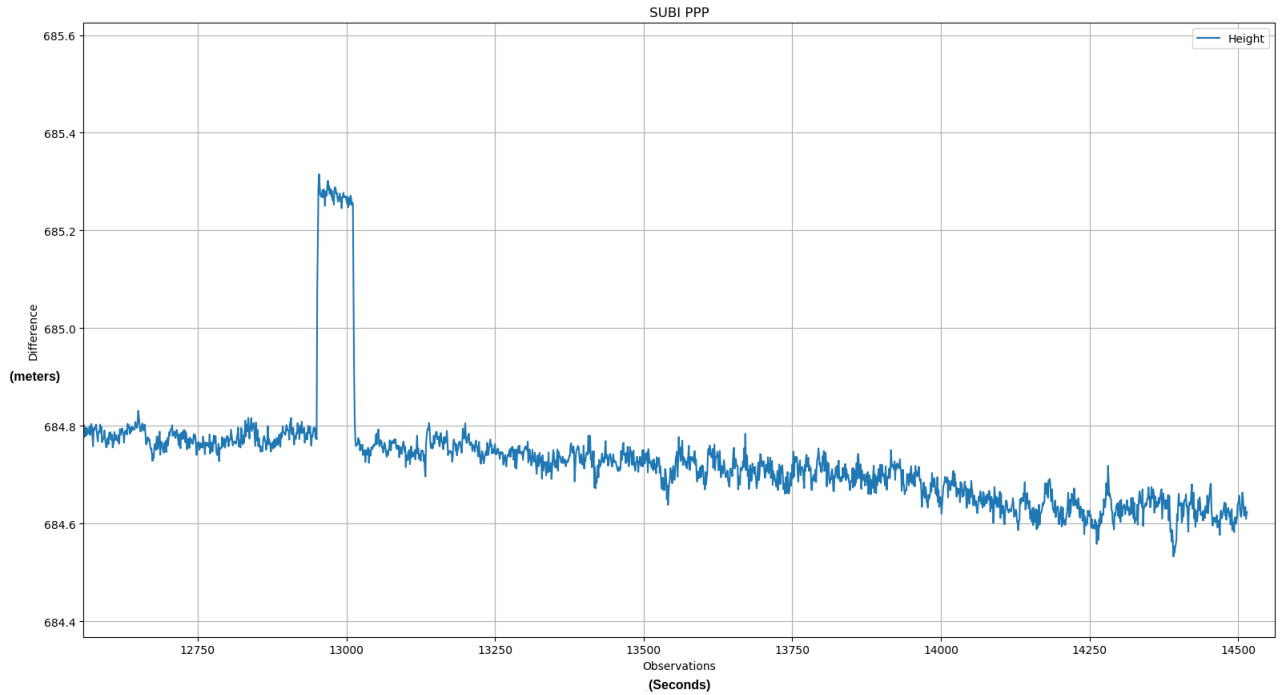

Figure 5.9: Rover Height zoomed.

With this experiment is possible to conclude that the changes were reflected in the solutions, using the Fix and Hold method.

5.2.5 PAGU station

For comparing the methods with JPL the station PAGU was used, as the solutions of JPL were available and the proposed method could be done in PAGU station as well.

PAGU Station

Position
 Latitude: 38.767312624°
 Longitude: 332.815663683°
 Ellipsoidal Height: 304.558 m
Displacement
 East: -0.001 m
 North: 0.000 m
 Vertical: -0.005 m
GPS Time
 Clock: 30/05/2022 11:09:40.0
Alerts

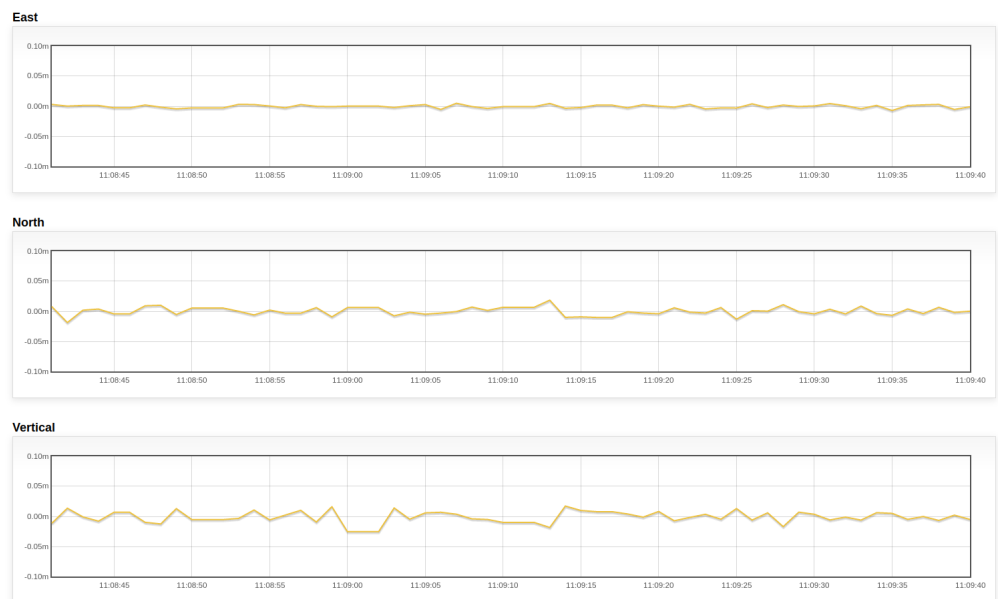

Computed by

 Jet Propulsion Laboratory
 California Institute of Technology
 Provided by

 Space & Earth Geodesy Analysis Laboratory

Figure 5.10: Solutions displayed in real-time.

Global RTK Corrections

The solutions of JPL are displayed in the website [SEG22a] and show the displacements between consecutive solutions as shown in Figure 5.10.

The PPP for the station PAGU, using the Fix and Hold option, the solutions obtained were as followed in Figure 5.11 for the day of the year 157. The solutions are consistent with few jumps.

The base station PAGU known position are X equals to 4429718.335, Y equals to -2275036.395 and Z equals to 3972396.943.



Figure 5.11: PAGU Method Fix and Hold for the full day.

The solutions from JPL for the same day are visible in graph 5.12. The solutions are very consistent during the day.

Global RTK Corrections

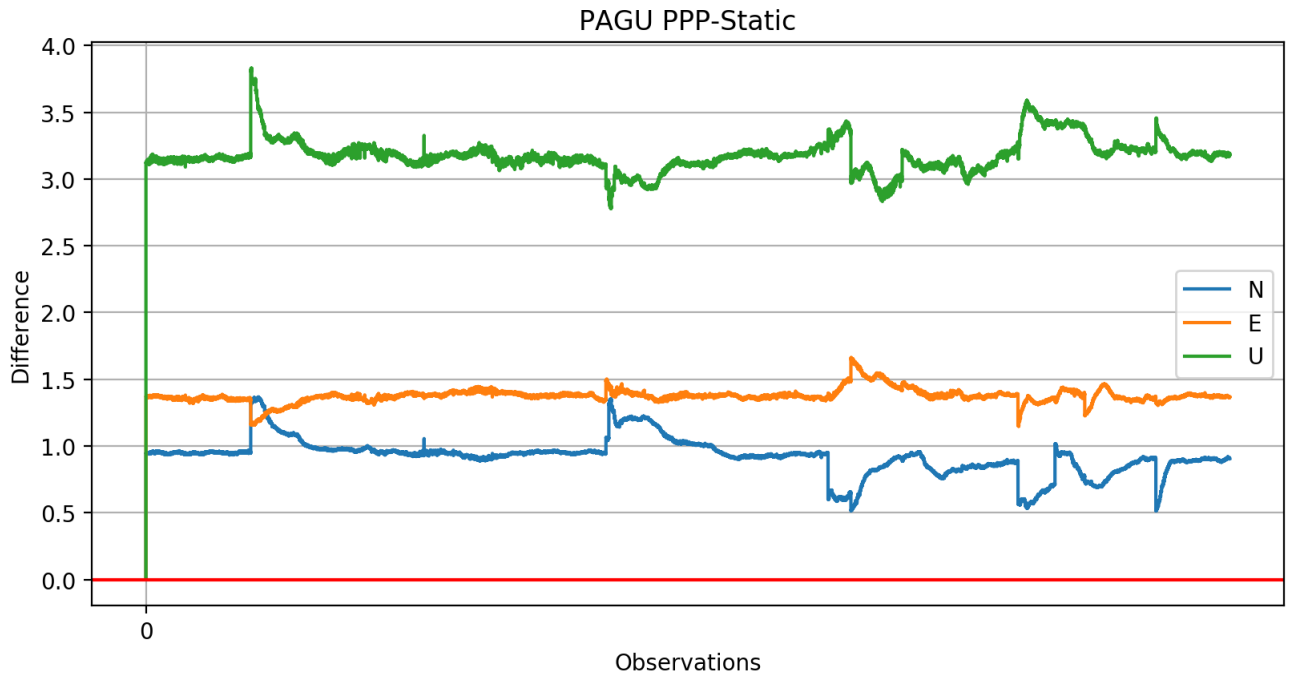

Figure 5.12: PAGU JPL solution for the full day.

The metrics for the solutions of the Fix and Hold option are in Tables 5.1, 5.2, 5.3 for the ENU reference system comparing to the reference position of the station. The residual for each day was calculated by computing the average value for all days and subtracting it to each day.

Metric	Standard Deviation (N)	Residual (N)
Doy 157	0.1340	0.0220
Doy 158	0.2010	-0.0750
Doy 159	0.1450	0.0540

Table 5.1: Statistics (standard deviation and residuals) for the North component of PAGU station.

Metric	Standard Deviation (E)	Residual (E)
Doy 157	0.0530	-0.0140
Doy 158	0.0280	0.0170
Doy 159	0.0610	-0.0040

Table 5.2: Statistics (standard deviation and residuals) for the East component of PAGU station.

Metric	Standard Deviation (U)	Residual (U)
Doy 157	0.1200	-0.2150
Doy 158	0.2000	0.0710
Doy 159	0.1000	0.1540

Table 5.3: Statistics (standard deviation and residuals) for the Up component of PAGU station.

The solutions obtained from JPL are displayed in the coordinates X, Y, Z and compared to the known position of the station.

Global RTK Corrections

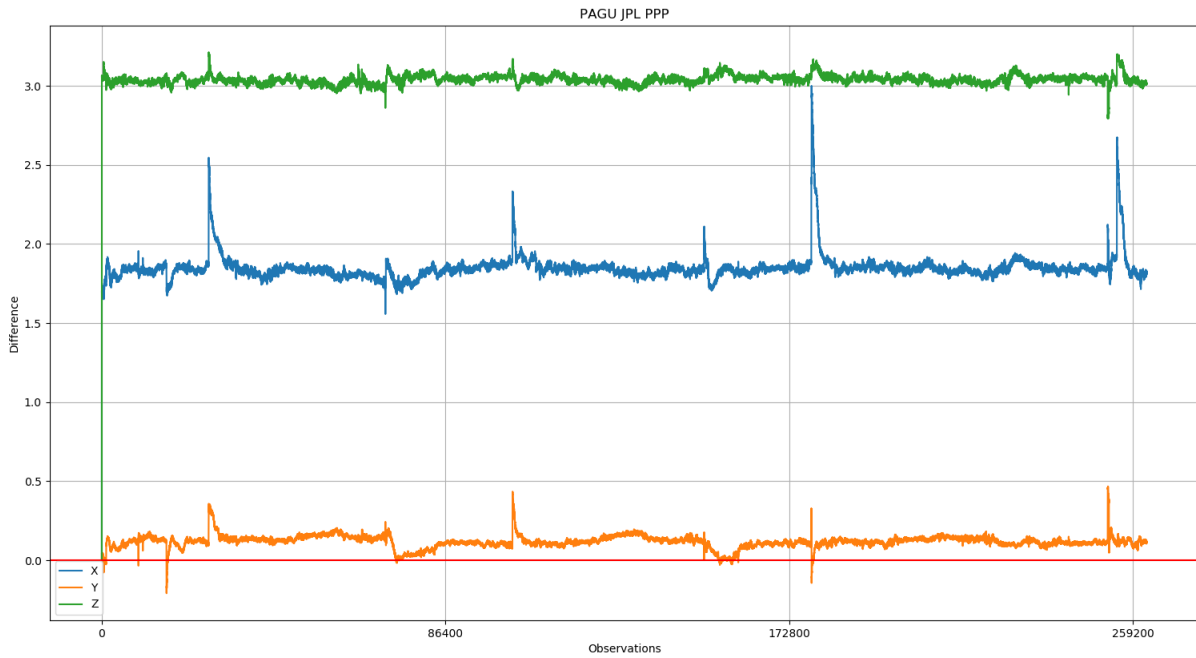

Figure 5.13: PAGU station position graph using the JPL solutions.

Figure 5.13 represents the solutions obtained from JPL using the coordinates X, Y, Z obtained and compare them to the known position of the station, obtaining this graph, where X is blue, Y orange and Z is green.

Metric	Standard Deviation of X	The mean (average) of X
Method	0.0946	4429720.2640
JPL	0.0857	4429720.1830
Difference	0.0089	0.0810

Table 5.4: Table comparing the two methods regarding the X field.

Metric	Standard Deviation of Y	The mean (average) of Y
Method	0.1114	-2275036.2980
JPL	0.0405	-2275036.2760
Difference	0.0709	-0.0220

Table 5.5: Table comparing the two methods regarding the Y field.

Metric	Standard Deviation of Z	The mean (average) of Z
Method	0.0288	3972400.0090
JPL	0.0278	3972399.9802
Difference	0.0010	0.0270

Table 5.6: Table comparing the two methods regarding the Z field.

Figure 5.14 was obtained by calculating the ENU of each solution, from both method and calculate the difference between them to examine the results, the closer to zero in the Y axis means that the output of the solutions are very similar. This comparison was made using the same number of observations from the same exact moment of start until the end, totaling more than three days of consecutive solutions in both methods.

Global RTK Corrections

In the beginning of the comparison is possible to see the time it takes to stabilize the solution from the proposed method.



Figure 5.14: NEU difference between methods for PAGU.

Metric	Standard Deviation (N)	Average (N)
Comparison	0.1130	0.0190

Table 5.7: Statistics comparing the two methods regarding the North component.

Metric	Standard Deviation (E)	Average (E)
Comparison	0.0730	-0.0310

Table 5.8: Statistics comparing the two methods regarding the East component.

Metric	Standard Deviation (U)	Average (U)
Comparison	0.1260	0.0800

Table 5.9: Statistics comparing the two methods regarding the Up component.

5.2.6 SSSV station

Following the solutions obtained from JPL, other station that SEGAL also receives the position solutions in real-time is SSSV, located in San Salvador in El Salvador. The average was calculated by obtaining the average values of all the days and subtracting it to each Day of year (Doy) corresponding.

The Table 5.10 represents the multiple different Doy that the solutions were received from JPL.

Global RTK Corrections

Metric	<i>Standard Deviation (N)</i>	<i>Average (N)</i>
Doy 73	0.0140	-0.0030
Doy 80	0.0160	0.0010
Doy 97	0.0160	-0.0030
Doy 110	0.0070	-0.0010
Doy 120	0.0090	0.0020

Table 5.10: Statistics (standard deviation and residuals) for the North component of SSSV station.

Metric	<i>Standard Deviation (E)</i>	<i>Average (E)</i>
Doy 73	0.0140	0.0020
Doy 80	0.0140	0.0040
Doy 97	0.020	-0.0020
Doy 110	0.0080	0.0000
Doy 120	0.0110	-0.0020

Table 5.11: Statistics (standard deviation and residuals) for the East component of SSSV station.

Metric	<i>Standard Deviation (U)</i>	<i>Average (U)</i>
Doy 73	0.0400	0.0000
Doy 80	0.0360	0.0080
Doy 97	0.0470	-0.0080
Doy 110	0.020	0.0060
Doy 120	0.0310	-0.0040

Table 5.12: Statistics (standard deviation and residuals) for the Up component of SSSV station.

5.2.7 JBEI station

The station JBEI located in São Jorge, Azores, were the method was applied. The metrics of the solutions are displayed. The average was calculated by obtaining the average values of all the days and subtracting it to each Doy corresponding.

Metric	<i>Standard Deviation (N)</i>	<i>Average (N)</i>
Doy 99	0.0240	0.0370
Doy 100	0.0060	0.0190
Doy 101	0.0040	0.0170
Doy 110	0.0910	-0.0710
Doy 111	0.0210	-0.0060

Table 5.13: Statistics (standard deviation and residuals) for the North component of JBEI station.

Metric	<i>Standard Deviation (E)</i>	<i>Average (E)</i>
Doy 99	0.0100	0.0040
Doy 100	0.0100	0.0080
Doy 101	0.0080	0.0090
Doy 110	0.0210	-0.0180
Doy 111	0.0090	-0.0050

Table 5.14: Statistics (standard deviation and residuals) for the East component of JBEI station.

Global RTK Corrections

Metric	Standard Deviation (U)	Average (U)
Doy 99	0.0400	-0.0280
Doy 100	0.0100	-0.0020
Doy 101	0.0080	-0.0150
Doy 110	0.0620	0.0480
Doy 111	0.0150	0.0000

Table 5.15: Statistics (standard deviation and residuals) for the Up component of JBEI station.

5.3 Discussion

The results obtained from the implementation of this method show that the method implemented using SSR messages are consistent, even though the accuracy compared to the known positions can deviate in the meters. Nevertheless, they are mostly consistent along the time, taking some time to stabilize the solutions but when stabilized the solutions do not vary by much consecutively.

Comparing to the solutions obtained from JPL to same stations and other stations the solutions do not deviate very much in the continuous mode, the main difference between methods is related to jumps in solutions from JPL observable in the graph 5.13, that do not happen in the continuous ambiguity resolution, this is due to the application of a Kalman filter, it is an algorithm developed to estimate the float ambiguities for short baseline scenarios. It has been used extensively in various applications related with positioning and navigation, showing its versatility in a large variety of noisy environments. That is the main reason that there are no jumps between solutions from the continuous mode.

However the Fix and Hold option for the ambiguity resolution gives solutions with bigger jumps in between solutions, this option is a must if the main goal is to monitor changes in the position of the station in real-time. The continuous mode for the ambiguity resolution takes into account the previous solutions from the beginning, taking a longer time to update the solutions. The continuous ambiguity resolution gives a more precise position at the cost of being unable to update to sudden changes to its position.

Chapter 6

Conclusions and Future Work

6.1 Conclusions

The applications of positioning in real-time are used in the everyday tasks of the population, the proliferation of pocket size receivers has enable a a wide range of possible applications. Especially with the amount of IoT devices coming into the market, with embedded sensors for acquiring, assessing and monitoring it's position the need for low-cost precise positioning is increasing significantly, and this method can help to achieve that goal.

Monitoring displacements in real-time of permanent GNSS stations has important applications for the safety of the populations since they are capable to sense deformations on human infrastructures or Earth's surface caused by earthquakes, volcanos, or landslides. The use of global corrections based on SSR messages overcomes many disadvantages of the traditional RTK methods. If the accuracy of the this new approach is still not at the same level, it is already enough to be applied in many monitoring applications with the advantages that they can be applied globally with similar accuracy not depending of the existence of reference stations in the vicinity. However SSR corrections still need some improvements, especially in the convergence time.

The implementation of the proposed method took a long research time on a new area until then unknown, leading to the discovery of new concepts an tools unfamiliar, leading to a personal grown in knowledge and abilities.

To conclude, the proposed method was implemented with success with the main goal of monitoring a station in real-time.

6.2 Future Work

Regarding future work, improvements can always be made in a new method that is still in development by many groups all over the world, leading a new implementations.

It would be important to include an algorithm to detect outliers when there are unexpected jumps in the solutions, normally caused by changes in the observed number and/or distribution of observed satellites. This type of outliers needs to be properly identified in order to not create false positives concerning true sudden movements (for example caused by earthquakes). This could be done by setting a minimum limit for occurred displacements in a specific component, or by defining a period of time that the displacement must be observed.

Another improvement could be to compute the displacements with respect to the national reference frame instead on ITRF. This could also permit to evaluate the usage of this

method for mapping and surveying purposes.

Finally, the seismic crisis of São Jorge presented new challenges. The implementation of an automatic service to monitor such dense networks that permit to analyse permanently the deformations in the covered area is an ultimate objective in the application of these methods. The common analysis of several stations can provide more robust conclusions and help to eliminate outliers.

Bibliography

- [Age21] European Global Navigation Satellite Systems Agency. Ppp-rtk market and technology report. 2021. xi, 9, 20
- [Age22] European Space Agency. Galileo high accuracy service [online]. 2022. Available from: [https://gssc.esa.int/navipedia/index.php/Galileo_High_Accuracy_Service_\(HAS\)](https://gssc.esa.int/navipedia/index.php/Galileo_High_Accuracy_Service_(HAS)). 20
- [ags22] agsgis. What is ntrip? [online]. 2022. Available from: https://www.agsgis.com/What-is-NTRIP_b_42.html. 10
- [Aim22] Aimil. Trimble netr9 (gnss) reference receiver [online]. 2022. Available from: <https://www.aimil.com/products/trimble-netr9-gnss-reference-receiver>. xi, 27
- [ard22] ardu-simple. Ntrip master hookup guide [online]. 2022. Available from: <https://www.ardu-simple.com/wifi-ntrip-master-hookup-guide/>. xi, 10
- [Ban18] Simon Banville. Precise point positioning with ambiguity resolution [online]. 2018. Available from: <https://igs.org/wg/ppp-ar/>. 25
- [BDVP⁺20] Eulalia Balestrieri, Luca De Vito, Francesco Picariello, Sergio Rapuano, and Ioan Tudosa. A review of accurate phase measurement methods and instruments for sinewave signals. *ACTA IMEKO*, 9:52, 06 2020. 15
- [BEY16] BEYOND. Gnss performance assessment and data recording guidelines in aviation [online]. 2016. Available from: <https://www.unoosa.org/pdf/icg/2016/icg11/wgc/09wgc.pdf>. 6
- [Ble16] Geoffrey Blewitt. *GPS, Reference Systems*, pages 1–4. 01 2016. 6, 8
- [C4G22] C4G. Collaboratory for geosciences [online]. 2022. Available from: <https://www.c4g-pt.eu/>. 16
- [CNE21] CNES. The real-time gnss stations network [online]. 2021. Available from: <http://www.ppp-wizard.net/ssr.html>. xi, 18
- [DB21] I. Fernandez Hernandez D. Blonski, J. De Blas. Galileo high accuracy service. 2021. Available from: https://www.unoosa.org/documents/pdf/icg/2021/Tokyo2021/ICG_CSISTokyo_2021_05.pdf. xi, 19
- [DEF14] DEPARTMENT OF DEFENSE. National geospatial-intelligence agency (nga) standardization document. 2014. Available from: <https://earth-info.nga.mil/php/download.php?file=coord-wgs84>. 8

- [dir22] dirsig. Coordinate systems [online]. 2022. Available from: <http://dirsig.cis.rit.edu/docs/new/coordinates.html>. xi, 7
- [dS16] Jorge Miguel Gonçalves Ferreira dos Santos. Avaliação da qualidade do posicionamento da rede gnss servir - cigeoe. *UNIVERSIDADE DE LISBOA, FACULDADE DE CIÊNCIAS*, 2016. xi, 16
- [dT] Direção-Geral do Território. Rede nacional de estações permanentes gnss [online]. Accessed: 2021-01-12. Available from: <https://renep.dgterritorio.gov.pt>. xi, 16
- [DuB95] Paul DuBois. *Using Csh and Tcsh*. O'Reilly Media, Inc., 1995. 29
- [EA415] EA4EOZ. Simple wgs 84 - ecef conversion functions [online]. 2015. Available from: <https://ea4eoz.blogspot.com/2015/11/simple-wgs-84-ecef-conversion-functions.html>. xi, 8
- [Edw03] Stuart Edwards. Gps for land surveyors, (2nd edition). by jan van sickle. *International Journal of Geographical Information Science - GIS*, 17:818–819, 01 2003. 14
- [Eve18] Tim Everett. Using ssr corrections with rtklib for ppp solutions [online]. 2018. Available from: <https://rtklibexplorer.wordpress.com/2018/05/08/using-ssr-corrections-with-rtklib-for-ppp-solutions/>. 21
- [Fero0] Rui Fernandes. Code written in GEODAC, 2000. 32
- [fMS13] Radio Technical Commission for Maritime Services. *RTCM STANDARD 10403.2, DIFFERENTIAL GNSS(GLOBAL NAVIGATION SATELLITE SYSTEMS) SERVICES – VERSION 3*. RTCM, 2 2013. xiii, 9
- [fOSA22] United Nations Office for Outer Space Affairs. Global navigation satellite systems [online]. 2022. Available from: <https://www.unoosa.org/oosa/en/ourwork/psa/gnss/gnss.html>. 4
- [Fou22] Rocky Enterprise Software Foundation. Rocky linux [online]. 2022. Available from: <https://rockylinux.org/>. 28
- [Geo15] Geo++. For network-rtk, ppp and ppp-rtk. *Geo++*, 2015. Available from: <https://www.mdpi.com/2072-4292/11/9/1001>. xi, 9, 21
- [GEO22] GEO++. Gnsmart for ssr broadcast [online]. 2022. Available from: <https://www.geopp.de/gnsmart-for-ssr-broadcast/#.2>
- [gis22] gisgeography. How gps receivers work – trilateration vs triangulation [online]. 2022. Available from: <https://gisgeography.com/trilateration-triangulation-gps/>. xi, 4

Global RTK Corrections

- [Gro15] Paul D. Groves. Principles of gnss, inertial, and multisensor integrated navigation systems, 2nd edition [book review]. *IEEE Aerospace and Electronic Systems Magazine*, 30(2):26–27, 2015. 3
- [GXD⁺05] Jinjun Guo, Liang Xu, Lianjun Dai, M. McDonald, Jianping Wu, and Yanying Li. Application of the real-time kinematic global positioning system in bridge safety monitoring. *Journal of Bridge Engineering - J BRIDGE ENG*, 10, 03 2005. xi, 14
- [IGS22a] IGS. International gnss services [online]. 2022. Available from: <https://igs.org/>. 22
- [IGS22b] IGS. Network [online]. 2022. Available from: <https://igs.org/network/>. xi, 19
- [IGS22c] IGS. Real-time service [online]. 2022. Available from: <https://connect.igs.org/rts>. 19
- [IGS22d] IGS. Rts products [online]. 2022. Available from: <https://igs.org/rts/products/>. 2
- [JPL17] JPL. Jpl/gdgps gnss full form orbit/clock message. 05 2017. Version 1.2. xiii, 25
- [Ker22] Michael Kerrisk. Linux manual page [online]. 2022. Available from: <https://man7.org/linux/man-pages/man1/nocat.1.html>. 28
- [Lan95] Richard B. Langley. Nmea 0183:a gps receiver interface standard. *Department of Geodesy and Geomatics Engineering University of New Brunswick*, 1995. Available from: <http://www2.unb.ca/gge/Resources/gpsworld.july95.pdf>. 26
- [LWL13] Tao Li, Jinling Wang, and Denis Laurichesse. Modeling and quality control for reliable precise point positioning integer ambiguity resolution with gnss modernization. *GPS Solutions*, 18, 07 2013. 25
- [MIR22] MIRASPACO. Miranet são jorge [online]. 2022. Available from: <https://sjorge.c4g-pt.eu/>. xi, 17
- [Mor80] H. Moritz. Geodetic reference system. *Bulletin géodésique*, 27, 1980. Available from: <https://doi.org/10.1007/BF02521480>. 6
- [nov22] novatel. What are global navigation satellite systems? [online]. 2022. Available from: <https://novatel.com/tech-talk/an-introduction-to-gnss/what-are-global-navigation-satellite-systems-gnss>. xi, 5
- [oF22] National Land Survey of Finland. Positioning service principle [online]. 2022. Available from: <https://www.maanmittauslaitos>.

fi/en/maps-and-spatial-data/positioning-services/
positioning-service-principle. 3

- [Org22a] Python Organization. Download python [online]. 2022. Available from: <https://www.python.org/downloads/>. 29
- [Org22b] Python Organization. The python wiki [online]. 2022. Available from: <https://wiki.python.org/moin/FrontPage>. 29
- [Org22c] TCSH Organization. Tcsh source code [online]. 2022. Available from: <https://github.com/tcsh-org/tcsh>. 29
- [RBoo] Benjamin Remondi and Grover Brown. Triple differencing with kalman filtering: Making it work. *GPS Solutions*, 3:58–64, 01 2000. 13
- [RG88] T.V. Ramabadran and S.S. Gaitonde. A tutorial on crc computations. *IEEE Micro*, 8(4):62–75, Aug 1988. 25
- [RJRG12] Chris Rizos, Volker Janssen, Craig Roberts, and Thomas Grinter. Precise point positioning: Is the era of differential gnss positioning drawing to an end? 2012. 22
- [RTC22] RTCM. Radio technical commission for maritime services [online]. 2022. Available from: <https://www.rtcn.org/>. 8
- [SEG22a] SEGAL. Pagu station solutions [online]. 2022. Available from: <http://segal.ubi.pt/realtime/PAGU/>. 44
- [SEG22b] UBI SEGAL. Segal portal [online]. 2022. Available from: <http://segal.ubi.pt/>. 29
- [Sep21] Septentrio. Septentrio polarx5 user guide [online]. 01 2021. Available from: https://www.septentrio.com/system/files/support/polarx5_user_manual_v2.2.pdf. 28
- [Sep22] Septentrio. Septentrio polarx5 [online]. 2022. Available from: <https://www.septentrio.com/en/products/gnss-receivers/reference-receivers/polarx-5>. xi, 28
- [Ser18] National Ocean Service. Gnss performances [online]. 2018. Available from: https://gssc.esa.int/navipedia/index.php/GNSS_Performances. 6
- [Ser22] National Ocean Service. The global positioning system, global positioning tutorial [online]. 2022. Available from: https://oceanservice.noaa.gov/education/tutorial_geodesy/geo09_gps.html. 3
- [Silo7] Teresa Sousa Silva. Error analysis in gnss receivers. *Instituto Superior Técnico, Lisbon*, 2007. 14

Global RTK Corrections

- [SMS⁺12] Andrea Stuerze, Leos Mervart, Wolfgang Söhne, Georg Weber, and Gerhard Wübbena. Real-time ppp using open cors networks and rtm standards. 03 2012. 22
- [Suv22] National Geodetic Suvey. The noaa cors network (ncn) [online]. 2022. Available from: <https://geodesy.noaa.gov/CORS/>. 11
- [TA22] T.Takasu and A.Yasuda. Brtklib: An open source program package for rtk-gps. <http://www.rtklib.com/rtklib.htm>, 2022. 25
- [Tak13] T. Takasu. Rtklib ver. 2.4.2 manual [online]. April 29, 2013. Available from: http://www.rtklib.com/prog/manual_2.4.2.pdf [cited 16 May 2022]. xi, 26
- [Ter20] Teria. Ssr, a "revolution" for gnss [online]. 2020. Available from: <https://www.reseau-teria.com/language/en/2020/03/10/ssr-a-revolution-for-gnss/>. 21
- [TRI10] TRIMBLE. *TRIMBLE NETR9 User Guide*. 05 2010. Available from: http://navgeotech.com/ftp/user_guide/um_NetR9_en.pdf. 27
- [UPKK20] I. Um, S. Park, H. T. Kim, and H. Kim. Configuring rtk-gps architecture for system redundancy in multi-drone operations. *IEEE Access*, 8:76228–76242, 2020. 14
- [WDG05] G. Weber, D. Dettmering, and H. Gebhard. Networked transport of rtm via internet protocol (ntrip). In Fernando Sansò, editor, *A Window on the Future of Geodesy*, pages 60–64, Berlin, Heidelberg, 2005. Springer Berlin Heidelberg. 10
- [wwh22] what-when how. Coordinate systems give meaning to spatial data (spatial data and the science of measurement) (the 3-d global spatial data model) [online]. 2022. Available from: <http://what-when-how.com/the-3-d-global-spatial-data-model/coordinate-systems-give-meaning-to-spatial-data-spatial-data-and-the-science/> xi, 7
- [Xu12] Hongtao Xu. Application of gps-rtk technology in the land change survey. *Procedia Engineering*, 29:3454 – 3459, 2012. 2012 International Workshop on Information and Electronics Engineering. Available from: <http://www.sciencedirect.com/science/article/pii/S1877705812005218>. 14
- [XX16] Guochang Xu and Y. Xu. *GPS: Theory, algorithms and applications, third edition*. 01 2016. 7
- [ZA12] Hansjörg Kutterer Chris Rizos Zuheir Altamimi, Tonie van Dam. Role and importance of the international terrestrial reference frame for sustainable development. 2012. Available from: <https://www.terrestrial-reference-frame.org/>

Global RTK Corrections

[//unstats.un.org/unsd/geoinfo/rcc/docs/rccap19/Side%20events/
IAG-GGOS-ITRF-report2UNRRC-10Oct2012.pdf](http://unstats.un.org/unsd/geoinfo/rcc/docs/rccap19/Side%20events/IAG-GGOS-ITRF-report2UNRRC-10Oct2012.pdf). 6