

WIRELESS FLEX SENSOR BELT NETWORKS FOR FOETAL MOVEMENT MONITORING IN LOW RISK PREGNANCIES

*Luís M. Borges*¹, *Norberto Barroca*¹, *Fernando J. Velez*¹, António S. Lebres²

¹ Universidade da Beira Interior, Instituto de Telecomunicações, Departamento de Engenharia Electromecânica Covilhã, Portugal, lborges@lx.it.pt; norberto.barroca@hotmail.com; fju@ubi.pt

² Universidade da Beira Interior, Departamento de Física, Covilhã, Portugal, lebres@ubi.pt

Abstract – In this work two flex sensor belts were produced to count the foetal movements in the last four weeks of pregnancy. While one is a standalone solution the other is a wireless flex sensor belt network one. A description of the type of sensors is followed by the discussion of the different types of acquisition and data treatment methodologies. The application to display the deformation angles is presented as well. The wireless sensor network solution is based on the IEEE 802.15.4 standard, and the hierarchical wireless network solutions include a Wi-Fi layer. Preliminary results highlight the need for accounting for mother respiration movements and actual experiences with pregnant woman will facilitate tuning the threshold-trigger, to improve the detection performance.

Keywords: Hierarchical Wireless Communications, WSAN, Tele-medicine, Foetal Monitoring

1. INTRODUCTION

The Smart Clothing for Health Monitoring and Sport Applications (Smart-Clothing) project addresses the interdisciplinary research on textile materials and wireless sensor and actuator networks (WSAN) in the context of human body monitoring combined with statistical methods for the data analysis and treatment [1]. It mainly aims at aiding in the monitoring of the foetal movement in the last four weeks of pregnancy. Besides the integration of sensors in the garment there is a need to have an hybrid communication system, organized in a hierarchical way, that allows for the delivery of the data collected from the garment wore by the pregnant woman to the health professional remotely based. In the first stage of this work, tests are being carried out by using several types of sensors integrated into a belt. The objective is to choose the one that is more reliable for the detection of foetal movement.

The need to monitor the foetal health in the periods between the medical sessions in low risk pregnancies are based in traditional protocols for counting the foetal movements felt by the mother [2]. Although the maternal perception is a relevant characteristic for the evaluation of the foetal health, the monitoring is hard to accomplish and can induce to errors caused by the mother's anxiety and concentration. Between the medical sessions that occur weekly during the last five weeks of pregnancy, the foetal

health can change suddenly. As a consequence, the majority of foetus fatalities at this stage of pregnancy occur in the low risk group. Therefore, it is very important to obtain an obstetric tracing, allowing for the identification of sudden changes in the foetus health by monitoring the foetus movements and the foetal heart rate (FHR).

In the Hospital, the foetal monitoring is done by using TocoCardiographie, whose equipment records the FHR and the uterus contractions. The FHR is determined by using an ultra-sound Doppler sensor (1 to 3 MHz) while the uterine contractions are detected with a pressure sensor. The foetal monitoring may be done at home by the pregnant women. They count the foetus movements (note that the pregnant woman feels 80% of the movements), which should be registered in a form for later analysis of the physician. There is in the market low cost portable equipments, based on the Doppler technology, which facilitate the FHR and the foetal movements monitoring by the pregnant woman [3]. They can be used beyond the 12th week of pregnancy and allows for recording the cardiac sounds. Other issue discussed in medicine is the use of equipments based on long exposition to ultra-sound technique that can pose possible risks over the foetus but their effects are not well known yet.

One example of how this theme of pregnancy monitoring is gaining importance in the research is the mentioned by the authors of [4], who describe an innovative remote monitoring decision support system. It can be used in the early diagnosis of pregnancy complications, through the effective and non-invasive monitoring of maternal and foetal electrocardiograms. Some patents on foetal monitoring are presented in [5], [6], [7].

One of the problems responsible for the possible occurrence of pregnancy complications is the failure of the monitoring rules by the pregnant woman. Frequently the pregnant woman does not account for the felt movements with the same quality as the health services; or even she does not attend to the medical sessions. Therefore, the main reason for the development of these easy to wear prototypes is because sometimes the pregnant woman is not able to give special attention to the monitoring and there is not a harmless device to perform this type of monitoring. This results in the need to develop automatic systems for foetal monitoring. Therefore, the development of easy to wear tele-medicine gear will allow for remotely monitoring pregnant women and the health of the babies they carry.

The remaining of this paper is organized as follows. Section 2 presents the sensor belt concept, describing in detail the first and second version of the belt. Section 3 presents initial results obtained by using both belts, i.e., the standalone and the wireless network versions, and gives some ideas to future implementation. Finally, Section 4 presents conclusions and suggestions for further work.

2. FLEX SENSOR BELT

2.1. Concept

After the application scenarios had been defined [8] the next step was to identify which type of sensor will be incorporated into the Smart-Clothing belt. To achieve this goal, several belts were made and compared to see which sensors are capable of detecting the foetal movement. All these belts are currently being tested and results will soon pop up from the tests [8].

One of the Smart-Clothing belt prototypes is based on the Flex sensor, Fig. 1, which has a variable printed resistor.

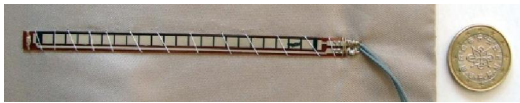

Fig. 1. Flex sensor incorporated in the Smart-Clothing belt.

The Flex sensor used in this project is from Spectra Symbol manufacturer and is based on resistive carbon elements. The Flex sensor achieves great form-factor on a thin flexible substrate. When the substrate is bent, the sensor produces a resistance output correlated to the bend radius – the higher the radius, the higher the resistance value, Fig. 2.

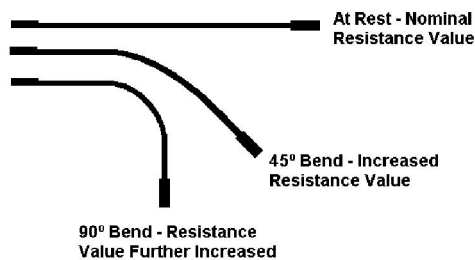

Fig. 2. Flex sensor with variable resistance values .

The characteristics of the Spectra Symbol sensor are: a) Lifetime larger than 1 million life cycle; b) Temperature range from -35 to +80 Celsius; c) Hysteresis value of 7%; d) Operation voltage from 3 to 12 V; e) Resistance Range from 10 to 22 k .

In this project two approaches were followed. One considers the belt with eight Flex sensors incorporated into it, an acquisition board to read the values from the sensors and software developed to display the deformation angles for each flex sensor. The other approach is an evolution of the first one and uses the same belt. However, instead of using wired connections, the data is being transmitted throughout a Wireless Sensor Network (WSN) composed by Crossbow IRIS motes. This WSN allows for correctly

receiving the data from the sensors in a computer while making the results available.

All the data from our application is saved by using a SQL database. SQL helps avoiding redundant and outdated data, and solves security problems related with the malicious or unauthorized access, as the data that comes from the belt of the pregnant woman must be protected from corruption.

2.2. Standalone Flex sensor Belt

The first version of the Flex sensors belt incorporates eight Flex sensors, Fig. 3.

A simple voltage divider is enough to operate this sensor as the manufacturer proposes a correspondence of standard values of the flexion angle to a certain value of resistance.

The Flex sensor manufacturer states that a resistance value of 10 k matches an angle of 0° while a value of 14 k matches an angle of 90° and a value of 22 k matches an angle of 180°.

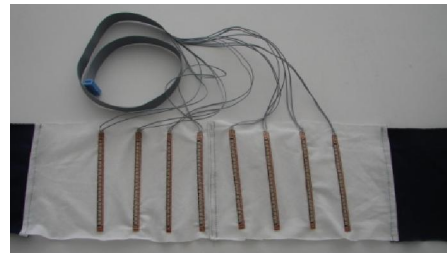

Fig. 3. Flex sensor belt.

The system diagram is presented in Fig. 4, where just one Flex sensor is presented. However, all eight sensors were connected to a single voltage divider. Besides the Flex sensor a button was incorporated to be pressed by the pregnant woman when she feels or detects the foetus moving. These events will be very useful for comparison purposes, as they enable a comparison with the movements detected automatically by the belt. An initial drawing of this system had the power supply connected to each voltage divider, but when the system was turn on the system failed because of not supporting enough current to hold on all the voltage dividers as well as the microcontroller.

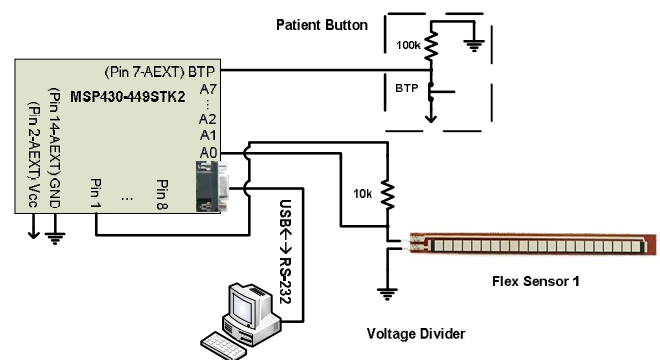

Fig. 4. Flex sensor belt diagram.

To overcome this limitation, the solution was to supply the V_{cc} voltage to the voltage divider by using external pin from the microcontroller and read the voltage from the

voltage divider using the Analog-to-Digital Converter (ADC) from the microcontroller. To compute the value of the resistance from the Flex sensor one uses the voltage divider formula as follows

$$R_{Flex} = \frac{R_1(V_{in} - V_{out})}{V_{out}}, \quad (1)$$

where R_{Flex} is the resistance value, R_1 is equal to 10 k , V_{in} is the V_{cc} value supplied to the voltage divider, and V_{out} is the voltage value from the voltage divider. The V_{cc} voltage supplied to the voltage divider is measured periodically by a routine that is located in the microcontroller, in order to compensate the battery losses during the system operation, and to achieve a better accuracy of the values from the Flex sensors.

For the conversion of the resistance value to the angle value, two formulas were used to extrapolate the angle values, as follows

$$\theta_1 [^\circ] = \frac{R_{Flex} - 10 * 10^3}{44,44}, \quad (2)$$

$$\theta_2 [^\circ] = \frac{R_{Flex} - 6001}{88,88}, \quad (3)$$

where θ_1 and θ_2 , are the angles for the corresponding Flex sensor resistance value.

Equation (2) is used when the resistance value is between 10 k and 14 k while equation (3) is used when the resistance value is between 14 k and 22 k .

These formulas were based on the theoretical and calibration curve of the Flex sensor, Fig. 5. The theoretical line is based on the resistance values and corresponding deflection angle supplied by the flex sensor manufacturer and the Calibration curve is the result of an experiment where the flex sensor was bent from 0 to 90 and the resistance value measured was registered at each 10 of bending increment.

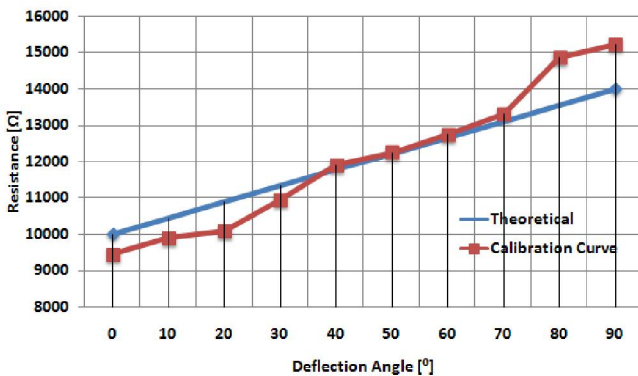

Fig. 5. Theoretical and Calibration curve of Flex sensor.

The MSP430-F449STK2 module, after acquiring the values for each Flex sensor, sends all the data to the computer (where all the angles are presented), and automatically counts the movements. It is important to

establish a packet protocol between the computer and the acquisition module. So the final version of the standalone Flex sensor belt uses only one data packet to transmit the deformation angles of the eight Flex sensors. This data packet is sent only at the end of the routine controlled by a timer in the microcontroller, in order to maintain a constant flow of data between the acquisition module and the computer. Besides this it was also implemented a routine in the microcontroller which is used to do the calibration of the Flex sensors. This packet is sent from the programme located in the computer to the acquisition module and has the ability to do the calibration of all the eight Flex sensors or only one Flex sensor.

2.3 Wireless Flex sensor Belt Network

By considering the work performed in the first version of Flex sensor belt, its second version considers remote monitoring functionalities by using the same set of sensors, Fig. 6.

To perform this remote monitoring, it was decided to use an IEEE 802.15.4 wireless sensor network that collects and transmit the remote vital data from the various sensors connected to the pregnant woman monitoring belt [9], [1].

In this case, we will monitor the foetal movements of a pregnant woman while data is being transmitted to a Mote Interface Board (MIB) that is directly connected to our Centralized Management of Resources (CMR). Our CMR is formed by a personal computer, an application which is responsible to display and save the measured data into the database, and a Wi-Fi module to transmit data across a Wireless Local Area Network (WLAN).

There are two different possibilities to receive and send information: one by only using IEEE 802.15.4 while the other considers two communications layers (IEEE 802.15.4 and 802.11 ones). If we want to collect as much data as possible from the patient questions like energy consumption and the trade-off between energy consumption/processing and communication capabilities are the most important topics to be focused.

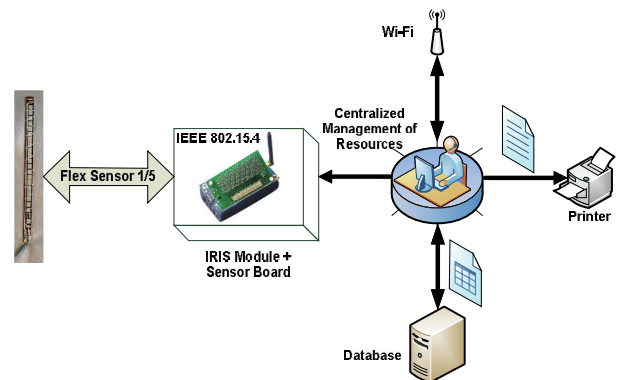

Fig. 6. Patient Monitoring using 802.15.4 Wireless Networking.

The reason IEEE 802.15.4 was chosen was not only because it makes radio and Medium Access Control (MAC) protocols available but also because it allows for focusing our application into the patient needs while ensuring an integrated and complete solution for sensor networking

based applications, including Analog-to-Digital conversion. There are five Flex sensors that are responsible for giving the information on the deformation angle caused by foetal movements. Hence, when the values for the voltage corresponding to the five different deformation angles are available, one needs to send the values to our application, and five ADCs are used. One possible scenario for this small scale wireless flex sensor belt network is at the waiting room of the health centre or clinic, where pregnant women wait to visit the physician.

In the second solution for this belt, another communication layer can be considered that allows for sending and receiving information that was collected from the IEEE 802.15.4 network through an IEEE 802.11 wireless network.

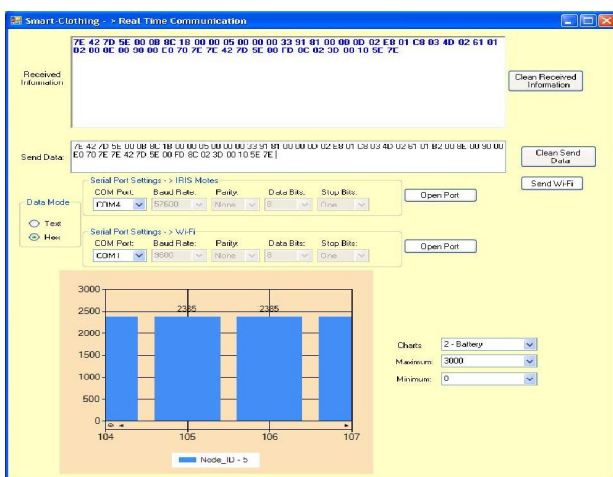

Fig. 7. Monitoring Application.

This solution was chosen because it constitutes a practical and interesting solution for network connectivity while offering limited mobility, flexibility, and low cost of deployment. An example is transmitting the data from our CMR to any computer that is in its range and that has IEEE 802.11 (Wi-Fi) network capabilities. A possible scenario is when the nurse is connected to the CMR while monitoring a patient with our application, Fig. 7.

If he/she needs to transmit the data to a physician that is located in another room, the data can be sent via the Wi-Fi network.

3. INITIAL RESULTS

Some initial tests were obtained for the first belt with a patient that was not a pregnant woman. The objective was to verify if the respiration movements or other type of motion artifact influence the angles of each Flex sensor in the belt. It was verified that the respiration movements were slightly felt. However, if the patient moves quickly then the sensors could detect the deformation from the belt. After these preliminary tests, the belts need to be tested in a pregnant woman, in order to detect the foetus movements and compare these occurrences with the one when the pregnant woman presses the button but the system does not detect the

movement. By considering these initial tests, a good idea will be to implement a routine which automatically defines the value for a detection threshold-trigger whose values will be tuned.

The final version of the Flex Sensor View software, Fig. 8, has some improvements, examples the capability to simultaneously show eight angles from the Flex sensor, the patient counter and the option to save the data in a log file for later treatment. This version enables the communication between the Computer and the acquisition by using a single interface a packet for all Flex sensors.

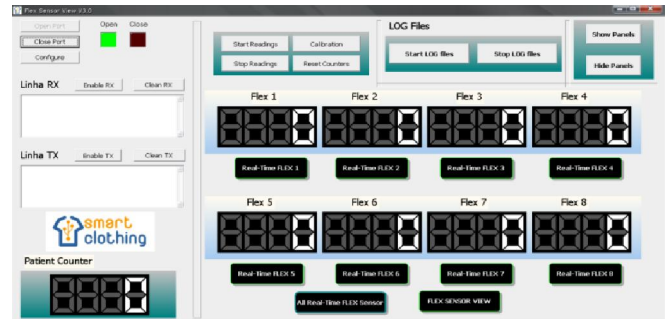

Fig. 8. Application Flex Sensor View Main window.

Figure 9 presents the application to display the sensors deformation angles.



Fig. 9. Application to display the deformation angles.

For each sensor, an independent threshold trigger can be defined individually, or a unique threshold value can be defined as a whole for all the sensors.

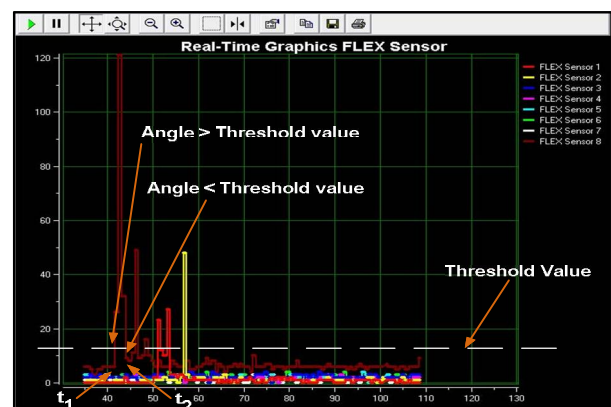

Fig. 10. Real-time graphics Flex Sensor plot.

With the consideration of this threshold-trigger even if the sensor detects some motion artefact a boundary can be established in order to tune when it should count the deformation angle as a foetal movement.

In Fig. 10 the value used for the global threshold is equal to 15 of angle deformation. This means that the automatic counter from each Flex sensor counts as a movement when the instant value of the Flex sensor angle is bigger than the threshold value in one time instant and smaller in the next time instant. As an example of how the automatic counter works is presented. Considering the Flex sensor 8 in the graphic in time instant t_1 the angle value is equal to 28 so the counter will count if this value decreases in the next time instant. In time instant t_2 the angle value is equal 8 so the automatic counter will add one unit to the counter of the Flex sensor 8.

4. CONCLUSIONS

This paper presents two versions of Flex Sensor Belts produced within the Smart-Clothing project, which aim at counting the movements of the foetus from a pregnant woman. Besides the standalone solution, where data can be saved into a memory card, we developed a wireless flex sensor belt network based on the IEEE 802.15.4 standard. A hierarchical wireless network with a Wi-Fi layer on top of the sensor network will allow for extra flexibility. The system gives real-time and continuous foetal monitoring while creating effective interfaces for querying sensor data and store all the medical record which can be later accessed by health professionals. Initial results show that the mother respiration movements or other type of motion artefact influence the angles of each flex sensor. The next step will be to test the belts in a pregnant woman in order to verify their performance and tune the threshold-triggers.

As future work a proposal is to implement other types of communications systems that could work together with the existing ones. Another proposal is to implement algorithms for noise and motion artefact signal suppression and to implement advanced algorithms for data treatment and aggregation.

ACKNOWLEDGMENT

This work was supported by UDR (Unidade de Detecção Remota), Department of Physics from University of Beira Interior, by IST-UNITE, by the PhD FCT (Fundação para a Ciência e Tecnologia) grant SFRH / BD / 38356 / 2007, by Fundação Calouste Gulbenkian, by “Projecto de Re-equipamento Científico” REEQ/1201/EEI/ 2005 (a Portuguese Foundation for Science and Technology project), and by the Smart Clothing project. Special thanks go to Ms. Andreia Rente and to Prof. Luisa Rita Salvado who helped in the belt production.

REFERENCES

[1] <http://www.e-projects.ubi.pt/smart-clothing/>

- [2] C. Gribbin, D. James, “Assessing fetal health”, *Current Obstetrics & Gynaecology*, Elsevier, vol. 15, n°. 4, pp. 221-227, 2005.
- [3] http://www.hibaby.co.uk/acatalog/Angelsound_Fetal_Doppler.html
- [4] Evaggelos Cz. Karvounis E., Papaloukas C., Tsipouras M., Bougia P., Dimitrios I., Naka K., “Remote maternal and fetal health monitoring during pregnancy”, in *Proc. of Information Technology Applications in Biomedicine (ITAB2006)*, Ioannina, Greece, Oct. 2006.
- [5] Maternal Fetal Monitoring System, US 7,333,850 B2, Feb.19, 2008.
- [6] Fetal Wellbeing Monitoring Apparatus and Pad Therefor, WO 2008/010215 A2.
- [7] Fetal Wellbeing Monitoring Apparatus and Pad Therefor, WO 2008/010215 A2.
- [8] Luís M. Borges, Andreia Rente, Fernando J. Velez, Luisa R. Salvado, António S. Lebres, J. Martinez Oliveira, Pedro Araújo, João Ferro, “Overview of Progress in Smart-Clothing Project for Health Monitoring and Sport Applications,” in *Proc. of ISABEL 2008 – First International Symposium on applied Sciences in Biomedical and Communication Technologies*, Aalborg, Denmark, Oct. 2008.
- [9] K. Sohraby, D. Minoli, T. Znati, *Wireless Sensor Networks Technology, Protocols, and Applications*, John Wiley & Sons, Hoboken, New Jersey, USA, 2007.
- [10] R. Verdone, D. Dardari, G. Mazzini and A. Conti, *Wireless Sensor and Actuator Networks- Technologies, Analysis and Design*, Academic Press, UK, 2008.