

Injection Valve EV 14

www.bosch-motorsport.com

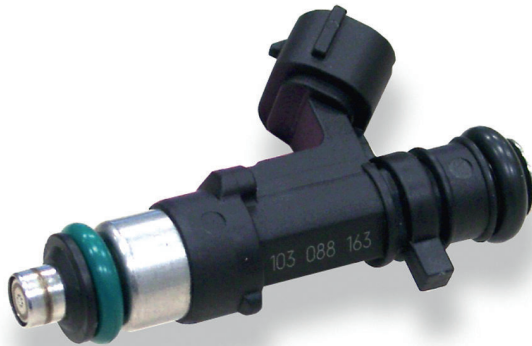

BOSCH
Invented for life



- ▶ Conical spray or 2-spray
- ▶ Flow rate at 3 bar: up to 1,023 cm³/min
- ▶ Spray angle 15 to 85°
- ▶ With or without extension

EV 14 injection valves are the latest revision of the EV 6 injection valve technology. EV 14 xT are the latest revision of the EV 12.

EV 14 is designed for a wide range of flow rates and spray patterns. Compact size and three standard versions simplify mounting in a variety of applications.

Technical Specifications

Mechanical Data

System pressure	Max. 8 bar
Weight	≤ 30 g
Installation lengths	33.6, 48.65 or 60.65 mm
Fuel input	Top-feed injector
Operating temperature	-40 to 110°C
Permissible fuel temperatures	≤ 70°C
Climate-proof corresponding to saline fog test DIN 50 021	
Housing design	Compact (C), Standard (S), Long (L)
Spray type	C (Conical Spray) or E (2-Spray)
Flow rate at 3 bar (n-heptane)	146 to 1,023 cm ³ /min 100 to 700 g/min
Spray angle α	15 to 85°

Bent angle γ	0 to 15°
Coil resistance	12 Ω
Fuel compatibility	E85 / M100 (after Methanol-operating the valves must be flushed with normal gasoline-fuel)

Electrical Data

Power supply	6 to 16.5 V
--------------	-------------

Connectors and Wires

Connectors	Jetronic, Sumitomo, Motorsport connectors
------------	---

Installation Notes

Please ask for more information before ordering.

Ordering Information

EV 14 CL, 116 g/min n-heptane
Order number **0 280 158 110**

EV 14 ES, 116 g/min n-heptane
Order number **0 280 158 200**

EV 14 CL, 150 g/min n-heptane
Order number **0 280 158 107**

EV 14 ES, 150 g/min n-heptane

Order number **0 280 158 013**

EV 14 CKxT, 237 g/min n-heptane

Order number **0 280 158 038**

EV 14 EL, 237 g/min n-heptane

Order number **0 280 158 116**

EV 14 CS, 387 g/min n-heptane

Order number **B 280 436 038-09**

EV 14 CS, 387 g/min n-heptane

Order number **B 280 436 038-10**

EV 14 ESxT, 429 g/min n-heptane

Order number **0 280 158 123**

EV 14 CS, 503 g/min n-heptane

Order number **B 280 436 038-08**

EV 14 CS, 503 g/min n-heptane

Order number **B 280 436 038-07**

EV 14 CKxT, 670 g/min n-heptane

Order number **0 280 158 040**

EV 14 CS, 670 g/min n-heptane

Order number **B 280 436 487-01**

Accessories

Clip for locking bush of plastic

Order number **2 431 314 021**

Clip for locking bush of steel

Order number **2 431 314 018**

Dimensions

C: Conical Spray

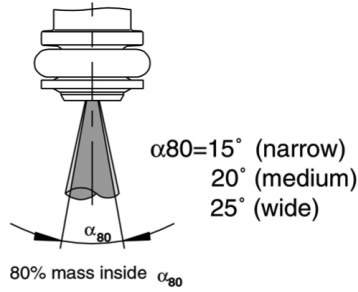

E: 2-Spray

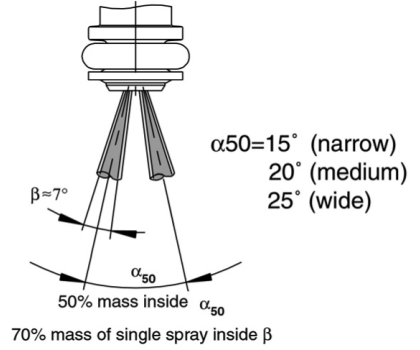

Angle between connection and spray level ($\delta = \text{delta}$):
 (only 2-spray preparation)

$\delta = 0^\circ - 360^\circ$ possible

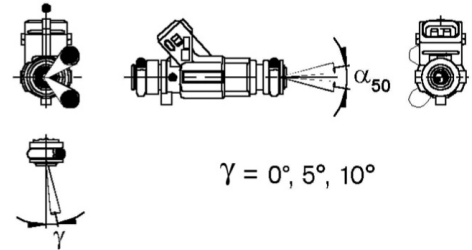
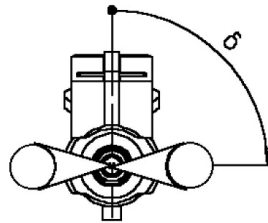

Spray Illustrations

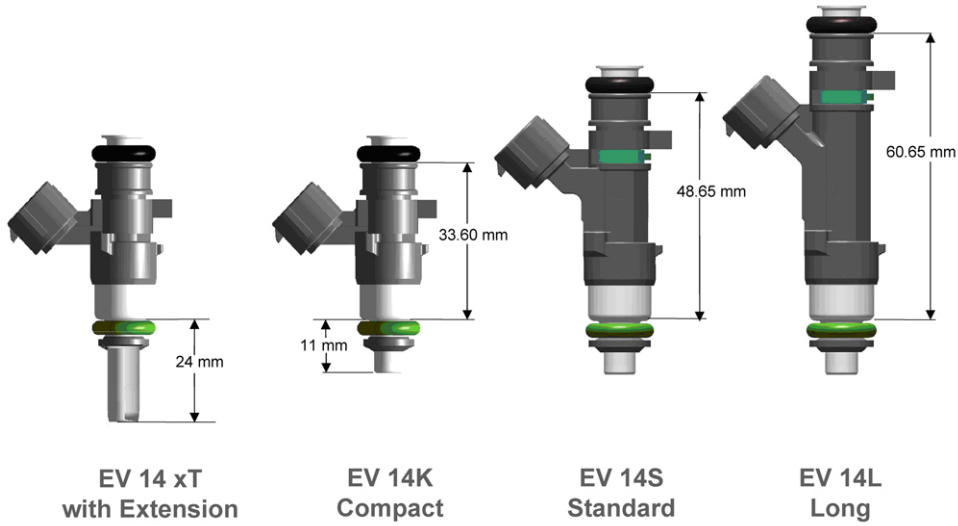

Housing Variations

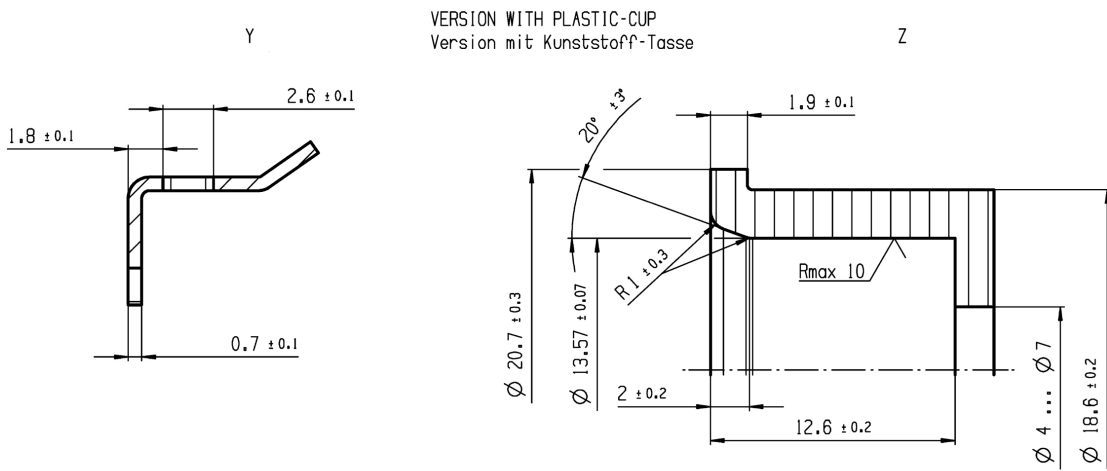
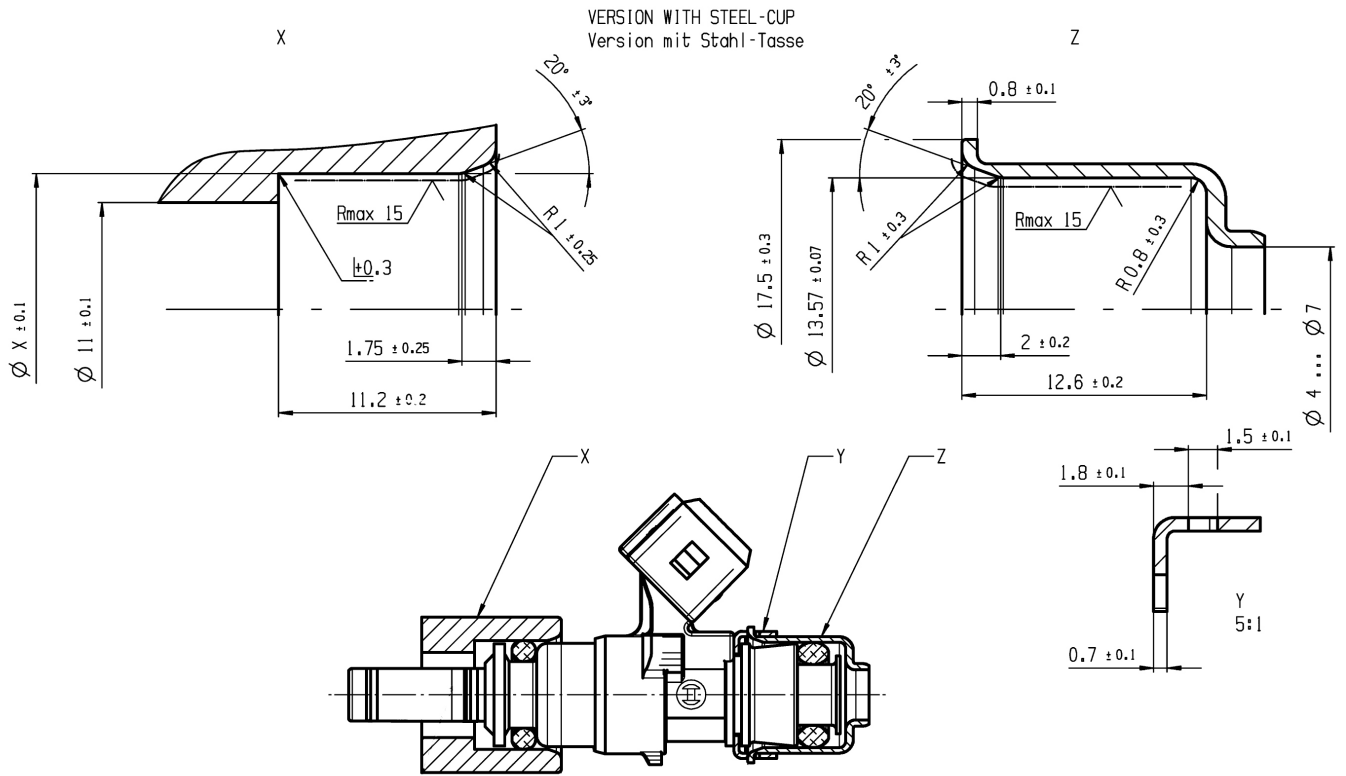

Mounting Instructions

EV 14 Variations

Variations of production type valves

Part Nr.	0 280 158 110	0 280 158 200	0 280 158 107	0 280 158 013	0 280 158 038
Flow rate/min	116 g/170 cm ³	116 g/170 cm ³	150 g/219 cm ³	150 g/219 cm ³	237 g/347 cm ³
Type	C	E	C	E	C
Housing	L	S	L	S	KxT
α	15°	15°	20°	19°	20°
γ	0°	0°	0°	0°	0°
δ	0°	90°	0°	90°	0°
Resistance	12 Ω	12 Ω	12 Ω	12 Ω	12 Ω

Part Nr.	0 280 158 116	0 280 158 123	0 280 158 040
----------	---------------	---------------	---------------

Flow rate/min	237 g/347 cm ³	429 g/627 cm ³	670 g/980 cm ³
Type	E	E	C
Housing	L	SxT	KxT
α	22°	25°	30°
γ	5°	0°	0°
δ	90°	90°	0°
Resistance	12 Ω	12 Ω	12 Ω

Further variations are available on request

Variations of Motorsport valves

Part Nr.	B 280 436 038-07	B 280 436 038-08	B 280 436 038-09	B 280 436 038-10	B 280 436 487-01
----------	------------------	------------------	------------------	------------------	------------------

Flow rate/min	503 g/736 cm ³	503 g/736 cm ³	387 g/566 cm ³	387 g/566 cm ³	670 g/980 cm ³
Type	C	C	C	C	C
Housing	S	S	S	S	S
α	70°	25°	70°	25°	30°
γ	0°	0°	0°	0°	0°
δ	-	-	-	-	0°
Resistance	12 Ω	12 Ω	12 Ω	12 Ω	12 Ω

Further variations are available on request.

Represented by:

Europe:

Bosch Engineering GmbH
Motorsport
Robert-Bosch-Allee 1
74232 Abstatt
Germany
Tel.: +49 7062 911 79101
Fax: +49 7062 911 79104
motorsport@bosch.com
www.bosch-motorsport.de

North and South America:

Bosch Engineering North America
Motorsport
38000 Hills Tech Drive
Farmington Hills, MI 48331-3417
United States of America
Tel.: +1 248 876 2977
Fax: +1 248 876 7373
motorsport@bosch.com
www.bosch-motorsport.com

Asia-Pacific:

Bosch Engineering Japan K.K.
Motorsport
18F Queen's Tower C, 2-3-5 Minato Mirai
Nishi-ku, Yokohama-shi
Kanagawa 220-6218
Japan
Tel.: +81 45 650 5610
Fax: +81 45 650 5611
motorsport@bosch.com

Australia and New Zealand:

Robert Bosch Pty. Ltd
1555 Centre Road
Clayton, Victoria, 3168
Australia
Tel.: +61 (3) 9541 3901
Fax: +61 (3) 9541 7225
motor.sport@au.bosch.com